

**Module- 1**

**Building Materials**

**Structure**

1.1 Introduction

1.2 Objective

1.3 Stone as building material

1.4 Bricks

1.5 Cement Concrete blocks

1.6 Mortar: types and requirements.

1.7 Timber as construction material

1.8 Fine aggregate

1.9 Coarse aggregate

1.10 Questions

1.11 Outcome

1.12 Future Study

notes4free.in

### 1.1 Introduction

- Materials which are required for construction of buildings are referred as building materials.
- Building materials are classified into three types
  - Natural Materials: - These are naturally occurring materials namely wood, stone, mud or clay etc.
  - Artificial materials: - These are man-made materials namely bricks, cement, glass & steel.
  - Composite materials: - These are combination of two or materials namely concrete, plywood etc.

### 1.2 Objective

- To study different types of building materials used for construction of buildings

### 1.3 Stones

#### Introduction

**Stones** are naturally occurring building materials which is widely use in construction of buildings. Nowadays it has become an important source of aggregate (coarse & fine) for manufacturing concrete. Most of the historic monuments that remain even today are made of stones. These are permanent in nature and prices go up if you change the shape and texture of stone.

Sources of stone are rock which is not homogeneous in nature, no definite chemical composition and shape. Therefore we can conclude, stones are one of the important building materials that all the Civil Engineers should be familiar with it.

#### Classification of rocks

Stones used for civil engineering works may be classified in the following three ways:

- Geological Classification
- Physical Classification
- Chemical Classification

#### Geological Classification

Based on their origin of formation stones are classified into three main groups

- (i) Igneous rocks
  - (ii) Sedimentary rocks and
  - (iii) Metamorphic rocks
- (i) **Igneous Rocks:** The inside portion of the earth's surface has high temperature so as to cause fusion by heat at even ordinary pressures. The molten or pasty rock material is known as the

magma occasionally tries to come out to the earth's surface through cracks or weak portions. The rocks which are formed by cooling of magma are known as the igneous rocks.

Different types of igneous rocks are

Plutonic rocks, hypabyssal rocks and volcanic rocks.

- (ii) **Sedimentary Rocks:** These rocks are formed by the deposition of products of weathering on the pre-existing rocks. All the products of weathering are ultimately carried away from their place of origin by the agents of transport. Such agents are frost, rain, wind, flowing water etc.
- (iii) **Metamorphic Rocks:** These rocks are formed by the change in character of the pre-existing rocks. The igneous as well as sedimentary rocks are changed in character when they are subjected to great heat and pressure. The process of change is known as the metamorphism.

### Physical Classification

Based on the structure, the rocks may be classified as:

- i. Stratified rocks
  - ii. Unstratified rocks
  - iii. Foliated rocks
- i. **Stratified Rocks:** These rocks are having layered structure. They possess planes of Stratification or cleavage. They can be easily split along these planes. Sand stones, lime stones, slate etc. are the examples of this class of stones.
  - ii. **Unstratified Rocks:** These rocks are not stratified. They possess crystalline and compact grains. They cannot be split in to thin slab. Granite, trap, marble etc. are the examples of this type of rocks.
  - iii. **Foliated Rocks:** These rocks have a tendency to split along a definite direction only. The direction need not be parallel to each other as in case of stratified rocks. This type of structure is very common in case of metamorphic rocks.

### Chemical Classification

On the basis of their chemical composition engineers prefer to classify rocks as:

- 1) Silicious rocks
  - 2) Argillaceous rocks and
  - 3) Calcareous rocks
- 1) **Silicious rocks:** The main content of these rocks is silica. They are hard and durable. Examples of such rocks are granite, trap, sand stones etc.
  - 2) **Argillaceous rocks:** The main constituent of these rocks is argil i.e., clay. These stones are hard and durable but they are brittle. They cannot withstand shock. Slates and laterites are examples of this type of rocks.

- 3) **Calcareous rocks:** The main constituent of these rocks is calcium carbonate. Limestone is a calcareous rock of sedimentary origin while marble is a calcareous rock of metamorphic origin.

### Requirements of good building stones

- 1) **Crushing Strength:** For a good building stone, the crushing strength should be greater than  $100\text{N/mm}^2$ .
- 2) **Appearance:** The stones which are to be used for face work should be decent in appearance and they should be capable of preserving their color uniformly for long time.
- 3) **Durability:** A good building stone should be durable. The various factors contributing to durability of a stone are its chemical composition, texture, resistance to atmospheric and other influences, location in structure etc.
- 4) **Facility of dressing:** The stones should be such that they can be easily carved, moulded, cut and dressed.
- 5) **Fracture:** for a good building stone, its fracture should be sharp, even, bright and clear with grains well cemented (means bonded) together.
- 6) **Hardness:** The co-efficient of hardness, as worked out in hardness test, should be greater than 17 for a stone to be use in road work. If it is in between 14 and 17, the stone is said to be medium hardness. If it is less than 14, stone is said to be poor hardness and such stones are not fit for road work.
- 7) **Percentage wear:** If wear is more than 3%, the stone is not satisfactory. If it is equal to 3%, stone is just tolerable. For a good building stone, the wear should be equal to or less than 3%.
- 8) **Resistance to fire:** The minerals composing stone should be such that shape of stone is preserved when fire occurs. The failure of stone in case of fire may be due rapid rise in temperature, sudden cooling and different coefficients of linear expansions of minerals.
- 9) **Seasoning:** the stones should be well seasoned before putting into use. Stones should be dried or seasoned before they are used in structural work. A period about 6 to 12 months is considered to be sufficient for proper seasoning.
- 10) **Specific gravity:** for a good building stone, its specific gravity should be greater than 2.7 or so. The heavy stones are more compact and less porous and they can be used for various engineering applications like dams, harbours etc.
- 11) **Texture:** A good building stone should have compact fine crystalline structure free from cavities, cracks or patches of soft or loose material.
- 12) **Toughness index:** In impact test, if the value of toughness index comes below 13, stone is not tough. If it comes between 13 and 19, stone is said to be moderately tough. If it exceeds 19, the toughness of stone is said to be high.
- 13) **Water absorption:** All the stones are more or less porous, but for a good building stone, percentage absorption by weigh after 24hrs should not exceed 0.6. The porous stones seriously affect the durability of stones.

14) **Weathering:** A good building stone should possess better weathering qualities. It should be capable of withstanding adverse effects of various atmospheric and external agencies such as rain, frost, wind etc.

### Dressing of stones

Stones after being quarried are to be cut into suitable sizes and with suitable surfaces. This process is known as the dressing of stones and is carried out for the following purposes.

- To get the desired appearance from stone work.
- To make the transport from quarry easy and economical
- To suit to the requirements of stone masonry
- To take advantage of local men who are trained for such type of work.

With respect to the place of work, dressing can be divided into two types namely

- Quarry dressing
- Site dressing

Advantages of dressing, if it is carried out @ quarry site.

1. At quarry site, it is possible to get cheap labour for the process of dressing of stones.
2. It is possible to sort out stones for different works, if quarry dressing is practiced.
3. The irregular and rough portions of the stones are removed which decrease the weight of stones and it also facilitates easy transportation of the stones.
4. The stones when quarried freshly contain quarry sap and hence they are comparatively soft and can be easily dressed.

Following are various types of finishes that can be obtained by dressing.

- 1) **Axed Finish:** The surface of hard stones such as granite is dressed by means of an axe. Such finish is termed as an axed finish.
- 2) **Boasted or droved finish:** In this type of finish, the boaster is used to make a non-continuous parallel marks on the stone surfaces. These marks may be horizontal, vertical or inclined. Boaster is chisel having an edge of width about 60mm.
- 3) **Chisel-draughted margins:** In order to obtain an uniform joints in stone work, the margins are placed which may be either squared or pitched or chamfered.
- 4) **Circular finish:** In this type of finish, the surface of stone is made round or circular as in case of a column.
- 5) **Dragged or combed finish:** In this type of finish, a drag or comb which is a piece of steel with a number of teeth is rubbed on the surface in all directions. This is suitable for soft stones.

- 6) **Furrowed finish:** In this type of finish, a margin of about 20mm width, is sunk on all edges of stone and the central portion is made to project about 15mm. a number of vertical or horizontal grooves about 10mm wide are formed in this projected portion .
- 7) **Moulded finish:** The surface of stone can be moulded in any desired shape so as to improve the appearance of the work. The mouldings can be made either by hand or machine.
- 8) **Hammer-dressed finish:** In this type of finish, stones are made roughly square or rectangle by means of a Waller's hammer. The hammer dressed stones have irregular corners, no sharp edges and have comparatively even surfaces so as to fit well in masonry.
- 9) **Plain finish:** In this type of finish, the surface is made approximately smooth with saw or with a chisel.
- 10) **Polished finish:** The surface of the stones such as granites, marbles etc. can be polished either with hand or with machine.
- 11) **Punched finish:** On the surface of stone, the depressions are made by using a punch. The surface of the stone takes the form of a series of hollows and ridges.
- 12) **Tooled finish:** The surface of stone is finished by means of a chisel and parallel continuous marks either horizontal, incline or vertical are left on the surface.

### Deterioration of stones

The stones with exposed faces are acted upon by various atmospheric and external agents so as to cause their deterioration. Following are the cause for deterioration of stones.

- 1) **Alternative wetness and drying:** The stones are made wet by various agencies such as rain, frost, dew etc. Such wet surface is dried by sunlight. It is found that stones subjected to such alternate wetness and drying wears out quickly.
- 2) **Frost:** In hill stations or very cold places, the moisture present in the atmosphere is deposited in the pores of stones. At freezing point, this moisture freezes and it expands in volume which causes the splitting of stone.
- 3) **Impurities in atmosphere:** The atmosphere contains various impurities which have adverse effects on stones. For instance, the acids and fumes are predominant in industrial areas. These impurities acts on carbonates of lime and causes deterioration.
- 4) **Living organisms:** Some living organisms like worms an bacteria act upon stones and deteriorate them. The organisms make holes in stones and thus weaken them. They also secrete organic acids which have a corrosive effect on stone minerals.
- 5) **Movement of moisture:** If stones of different variety such as limestone and sandstone are used side by side in the same structure, the chemicals formed by the action of atmospheric agents on one stone may move to the other and cause deterioration of both stones.
- 6) **Nature of mortar:** The nature of mortar used as a binding material in stone masonry may be such that it may react chemically with any one of the constituents of stones and thus it may lead to the disintegration of stones.
- 7) **Rain water:** The action of rain water on stones is two-fold – physical and chemical.

The rain wets the surface of stone and it is dried by sunlight. Such alternate wetness and drying results in the disintegration of stones. This is the physical action of water.

The rain water, as it descends through the atmosphere to the surface of earth, absorbs carbon dioxide (CO<sub>2</sub>), hydrogen sulphide (H<sub>2</sub>S) and other gases present in the atmosphere. These gases act adversely on stones and they cause decay of stones. This is the chemical action of rain water.

- 8) **Temperature variations:** the rise of temperature results in expansion of stones. The fall of temperature causes contraction of stones. If rise and fall of temperatures are frequent, the stones are easily deteriorated because of the setting up internal stresses.
- 9) **Vegetative growth:** The creepers and certain trees develop on stone surface with their roots in joints between stones. Such roots attract moisture and keep the stone surface damp. At the same time they try to expand. Such actions accelerate the decay of stones.
- 10) **Wind:** The wind contains fine particles of dust. If it is blowing with high velocity, such particles will strike against the stone surface and thus the stones will be decayed. The wind also allows rain water to enter pores of stones with force. Such water on freezing expands and splits the stones.

### Preservation of stones

The decay of building stones of inferior quality to some extent prevented if they are properly preserved. For this purpose, the preservatives are applied on the stone surfaces. An ideal preservative has the following properties:

1. It does not allow moisture to penetrate the stone surface.
2. It does not develop objectionable color.
3. It hardens sufficiently in order to resist the atmospheric agents.
4. It is easily penetrated in stone surface.
5. It is economical
6. It is non-corrosive and harmless.
7. It remains effective for long time after drying.
8. Its application on stone surface is easy.

The choice of a preservative depends on chemical composition and location of structure.

Following are the preservatives which are commonly adopted to preserve the stone:

- (i) **Coal tar:** If coal tar is applied on stone surface, it preserves stone. But the color of coal tar produces objectionable appearance and surface coated with coal tar absorbs heat of the sun. Hence this preservative is not generally adopted because it spoils the color of the stone.
- (ii) **Linseed oil:** This preservative may be used either as raw linseed oil or boiled linseed oil. The raw linseed oil does not disturb the original shade of stone. But it requires frequent renewal, usually once in year. The boiled linseed oil lasts for a long period, but it makes the stone surface dark.

- (iii) **Paint:** An application of paint on stone surface serves as a preservative. The paint changes the original color of the stone. It is applied under pressure, if deep penetration is required.
- (iv) **Paraffin:** This preservative may be used alone or it may be dissolved in naphtha and then applied on stone surface. It changes the original color of tone.
- (v) **Solution of alum & soap:** The alum and soft soap are taken in proportion of about 0.75N and 0.5N respectively and they are dissolved in a liter of water. This solution when applied on stone surface it acts as preservative.
- (vi) **Solution of baryta:** A solution of barium hydroxide  $\text{Ba}(\text{OH})_2$  when applied on stone surface acts as preservative. This is used when the decay of stone is mainly due to calcium sulphate.

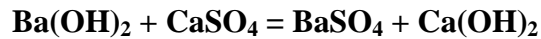

The barium sulphate is insoluble and it is least affected by atmospheric agents.  $\text{Ca}(\text{OH})_2$  absorbs  $\text{CO}_2$  from atmosphere and forms  $\text{CaCO}_3$  which adds to the strength to the stones.

----- XXXXXX -----

## 1.4 Bricks

### Introduction

**Bricks** are obtained by moulding clay in rectangular blocks of uniform size and then by drying and brining these blocks.

As bricks are of uniform size, they can be properly arranged and further as they are light in weight, no need of any lifting equipments for them. The bricks do not require any dressing and the art of laying bricks is simple, so that it can be carried out with the help of unskilled labors. Thus, at places where stones are not easily available and if plenty of clay is available we go for manufacturing the bricks. Thus bricks replace stones.

### Classification of brick earth

- 1) **Loamy, mild or sandy clay:** This type of earth consists of considerable amount of free silica in addition to alumina. The presence of sand helps in preventing cracking, shrinkage and warping of bricks. The addition of lime in such clay helps to fuse sand and there by increases the hardness of bricks.
- 2) **Marls, chalky or calcareous clay:** This clay consists of considerable amount of chalk in addition to alumina and silica. Such clay generally makes good bricks. But to avoid undesirable effects of excess lime, the sand is sometimes added to such clay.
- 3) **Plastic, strong or pure clay:** This clay consists of alumina and silica which is sometimes referred as strong or fat clay. The raw bricks will cracks, shrink and warp during drying, if pure clay alone is used in making of bricks. Hence such clay is corrected by the addition of sand and ash. The sand prevents shrinkage and ash provides lime to act as flux.



**Manufacturing of clay bricks**

Following are the considerations which governs the selection of brick field for manufacturing of bricks:

1. It should be linked up with communicating roads so that the materials can be conveyed easily.
2. It should be situated on a plain ground
3. It should be selected in such a way that the earth required for manufacturing of bricks is readily and easily available.
4. It should offer all the facilities to the workers employed in the manufacturing process.

In the process of manufacturing bricks, the following four distinct operations are involved.

- a) Preparation of clay
- b) Moulding
- c) Drying
- d) Burning

**Preparation of clay:** The clay for bricks is prepared in the following order

**Unsoiling:** The top layer of soil about 200mm in depth is taken out and thrown away. The clay in top soil is full of impurities and hence is to be rejected for the purpose of preparing bricks.

**Digging:** The clay is then dug out from the ground. It is spread out on the leveled ground, just a little deeper than the general level of ground. The height of heaps of clay is about 600mm to 1200mm.

**Cleaning:** The clay as obtained in the process of digging should be cleaned of stones, pebbles, vegetative matter etc. If these particles are in excess, the clay is to be washed and screened. Such a process naturally will prove to be troublesome and expensive. The lumps of clay should be converted into powder form in the earth crushing roller.

**Weathering:** The clay is made loose and any ingredient to be added to it, is spread out at its top. The blending indicates intimate or harmonious mixing. It is carried out by taking small portion of clay every time and turning the mixture up and down in the vertical direction. The blending makes clay fit for the next stage of tempering.

**Tempering:** In the process of tempering, the clay is brought to a proper degree of hardness and it is made fit for the next operation of moulding. The water in required quantity is added to clay and the whole mass is kneaded or pressed under the feet of men or cattle. The tempering should be done exhaustively to obtain homogeneous mass of clay of uniform character.

2) **Moulding:** The Clay which is prepared as above is then sent for the next operation of moulding. Following are the two ways of moulding:

1) **Hand Moulding:** In case of hand moulding, the bricks are moulded by hand i.e., manually. It is adopted where manpower is cheap and is readily available for the manufacture process of bricks on a small scale. The moulds are rectangular boxes which are opened at both top and bottom. They may be of wood or steel.

A typical wooden mould is shown in fig. it should be prepared from well seasoned wood. The longer sides are kept slightly projecting to serve as handles. The strips of brass or steel are sometimes fixed on the edges of wooden moulds to make them more durable.

A typical steel mould is shown in fig. It is prepared from the combination of steel plates and channels. It may even be prepared from steel angles and plates. The thickness of steel mould is generally 6mm. They are used for manufacturing bricks on large scale. The steel moulds are more durable than wooden moulds and they turn out bricks of uniform size.

The bricks shrink during drying and burning. Hence the moulds are made larger than size of fully burnt bricks. The moulds are therefore made longer by about 8 to 12 percent in all directions.

The bricks prepared by hand moulding are of two types

- **Ground-moulded bricks:** The ground is first made level and fine sand is sprinkled over it. The mould is dipped in water and placed over the ground. The lump of tempered clay is taken and it is dashed into the mould. The clay is pressed or forced in the mould in such a way that it fills all the corners of mould. The extra or surplus clay is removed either by wooden strike or metal strike or frame with wire. A strike is a piece of wood or metal with sharp edge. It is to be dipped in water every time.

The mould is then lifted up and the raw bricks are left on the ground. The mould is dipped in water and it is placed just near the previous brick to prepare another brick. The process is repeated till the ground is covered with raw bricks.

A brick moulder can mould 750 bricks per day with working period of 8hrs. When such bricks become sufficiently dry, they are carried and placed in the drying sheds.

The bricks prepared by dipping the mould in water every time are known as the **slop-moulded bricks**. The fine sand or ash may be sprinkled on the inside surface of mould instead of dipping it water. Such bricks are known as sand-moulded bricks and they have sharp and straight edges.

- **Table moulded bricks:** The process of moulding these bricks is just similar as above. But in this case, the moulder stands near a table of size about 2m X1m. the clay, mould, water pots, stock board, strikes and pallet boards are placed on this table. The bricks are moulded

on the table and sent for the further process of drying. However the efficiency of moulder decreases gradually because of standing at same place for long duration. The cost of brick moulding also increases when table moulding is adopted.

**2) Machine moulding:** The moulding may also be achieved by machine. It proves to be economical when bricks in huge quantity are to be manufactured at the same spot in a short time. It is also helpful for moulding hard and strong clay. These machines are broadly classified into two categories:

**a) Plastic clay machines:** Such machines contain a rectangular opening of size equal to length and width of a brick. The pugged clay is placed in the machine and as it comes out through the opening, it is cut into strips by wires fixed in frames. The arrangement is made in such a way that strips of thickness equal to that of the brick are obtained. As the bricks are cut by wire, they are called **wire cut bricks**.

**b) Dry clay machines:** In these machines, the strong clay is first converted into powder form. A small quantity of water is then added to form a stiff paste. Such paste is placed in mould and pressed by machine to form a hard and well shaped bricks. These bricks are known as the pressed bricks and they do not practically require drying. They can be sent directly to the process of burning.

The wire cut bricks and pressed bricks have regular shape, sharp edges and corners. They have smooth external surfaces. They are heavier, stronger and exhibit uniform dense texture than ordinary hand-moulded bricks.

**(i) Drying:** The damp brick, if burnt, are likely to be cracked and distorted. Hence the moulded bricks are dried before they are taken into next step of operation i.e., burning. For drying, the bricks are arranged longitudinally in stacks (means racks) of width equal to two bricks. A stack may contain 8 to 10 tiers. The bricks are arranged along and across the stacks in alternate layers. All bricks are placed on edge. The bricks are allowed to dry till they become hard with moisture content of about 2% or so.

**a. Artificial burning:** The bricks are generally dried by natural process. But when bricks are to be rapidly dried on a large scale, the artificial drying may be adopted. In such case, the moulded bricks are allowed to pass through dryers which are in the form of tunnels or hot channels or floors. Such dryers are heated with the help of special furnaces or by the hot flue gases. The tunnel dryers are more economical compared to hot floor dryers.

**b. Circulation of air:** The bricks in stacks should be arranged in such a way that sufficient air space is left between them for circulation of air.

**c. Drying yard:** For the drying purpose, special drying yards should be prepared. It should be slightly on a higher level and it is desirable to cover it with sand. Such an arrangement would prevent the accumulation of rain water.

**d. Period for drying:** The time required by moulded bricks to dry depends on prevailing weather conditions. Usually it takes about 3 to 10 days for bricks to become dry.

- e. **Screens:** It is to be seen that bricks are not directly exposed to the wind or sun for drying. Suitable screens, if necessary, may be provided to avoid such situations.
- (ii) **Burning:** This is a very important operation in the manufacturing process of bricks. It imparts hardness and strength to the bricks and makes them dense and durable. The bricks should be burnt properly. If bricks are over burnt, they will be brittle and hence break easily. If they are under burnt, they will be soft and hence cannot carry loads. When the temperature of dull red heat, about  $650^{\circ}\text{C}$ , is attained, the organic matter contained in the brick is oxidized and also the water of crystallization is driven away. But heating of bricks is done beyond this limit for the following purposes
1. If the bricks are cooled after attaining the temperature of about  $650^{\circ}\text{C}$ , the bricks formed will absorb moisture from the air and get rehydrated.
  2. The reactions between the mineral constituents of clay are achieved at higher temperature and these reactions are necessary to give new properties such as strength, hardness, less moisture absorption, etc. to the bricks.

When the temperature of about  $1100^{\circ}\text{C}$  is reached, the particles of two important constituents of brick clay minerals namely, alumina and sand, bind themselves together resulting in the increase of strength and density of bricks. Further heating is not desirable and if the temperature is raised beyond  $1100^{\circ}\text{C}$ , a great amount of fusible glassy mass is formed and the bricks are said to be vitrified. The bricks begin to lose their shape beyond a certain limit of vitrification.

The burning of bricks is done either in clamps or in kilns. The clamps are temporary structures and they are adopted to manufacture bricks in small quantity to serve a local demand or a specific purpose. The kilns are permanent structures and they are adopted to manufacture bricks on a large scale.

### Qualities of good brick

1. The bricks should be table-moulded, well-burnt in kilns, copper-colored, free from cracks and with sharp and square edges. The color should be uniform and bright.
2. The bricks should be uniform in shape and should be of standard size.
3. The bricks should give a clear metallic ringing sound when struck with each other.
4. The bricks when broken or fractured should show a bright homogenous and uniform compact structure free from voids.
5. The bricks should not absorb water more than 20 percent by weight for I class brick and 22 percent by weight for II class brick when soaked in water for 24hrs.
6. The bricks should be sufficiently hard. No impression should be left on brick surface, when it is scratched with finger nail.
7. The bricks should not break into pieces when it is dropped on hard ground from a height of 1 meter.
8. The bricks should have low thermal conductivity and they should be sound-proof.

9. The bricks when soaked in water for 24hrs should not show deposits of white salts when allowed to dry in shade.
10. No brick should have the crushing strength less than  $3.5 \text{ N/mm}^2$ .

### Tests on Bricks

- (1) **Absorption:** A brick is taken and it is weighed dry. It is then immersed in water for a period of 16hrs. It is weighed again and the difference in weight indicates the amount of water absorbed by brick. It should not in any case exceed 20% of weight of dry brick.
- (2) **Crushing strength:** The crushing strength of a brick is found out by placing it in a compression testing machine. It is pressed till it breaks. As per the code IS: 1077-1970, the minimum crushing strength should not be less than  $3.5 \text{ N/mm}^2$ . The brick with crushing strength of about 7 to  $14 \text{ N/mm}^2$  are graded as A and those having greater than  $14 \text{ N/mm}^2$  are graded as AA.
- (3) **Hardness:** In this test, a scratch is made on brick surface with the help of a finger nail. If no impression is left on the surface, the brick is treated to be sufficiently hard.
- (4) **Presence of soluble salts:** the soluble salts, if present in bricks, will cause efflorescence on the surface of bricks. For finding out the presence of soluble salts in a brick, it is immerse in water for 24hrs. It is then taken out and allowed to dry in shade. The absence of grey or white deposits on its surface indicates the absence of soluble salts.

If the white deposits cover about 10% surface, the efflorescence is said to be slight and it is considered as moderate, when the white deposits cover about 50% o surface. If grey or white deposits are found on more than 50% of surface, the efflorescence becomes heavy and it is treated as serious.

- (5) **Shape and size:** In this test, a brick is closely inspected. It should be of standard size and its shape should be truly rectangular with sharp edges. For this purpose, 20 bricks (19cm X 9cm X 9cm) are selected at random and they are stacked lengthwise, along the width and along the height.

For good quality bricks, the results should be within the following permissible limits.

Length: 3680mm to 3920mm

Breadth: 1740mm to 1860mm

Height: 1740mm to 1860mm

- (6) **Soundness:** In this test, the two bricks are taken and they are strucked with each other. The bricks should not break and a clear ringing sound should be produced.
- (7) **Structure:** A brick is broken and its structure is examined. It should be homogeneous, compact and free from any defects such as holes, lumps etc.

**Classification of bricks**

He bricks can be broadly classified into two categories as follows:

1. **The un-burnt or sun-dried bricks** are dried with the help of heat received from sun after the process of moulding. These bricks can only be used in the construction of temporary and cheap structures. Such bricks should not be used at places where they are exposed to heavy rains.
2. The bricks used in construction field are **burnt bricks** and they are classified into following four categories:

**I Class Bricks:**

- These bricks are table-moulded and of standard shape and they are burnt in kilns.
- The surface and edges of the bricks are sharp, square, smooth and straight.
- They satisfy all the qualities of good bricks which are mentioned earlier.
- These bricks are used for superior work of permanent nature.

**II Class Bricks:**

- These bricks are ground-moulded and they are burnt in kilns.
- The surface of these bricks is somewhat rough and shape is also straightly irregular.
- These bricks may have hair-cracks and their edges may not be sharp and uniform.
- These bricks are commonly used at places where brick work is to be provided with a coat of plaster.

**III Class Bricks:**

- These bricks are ground-moulded and they are burnt in clamps.
- These bricks are not hard and they have rough surfaces with irregular and distorted edges.
- These bricks give dull sound when strucked with each other.
- They are used for unimportant and temporary structures and at places where rainfall is not heavy.

**IV Class Bricks:**

- These are over-burnt bricks with irregular shape and dark colored.
- These bricks are used as aggregate for concrete in foundations, floors, roads etc.
- Because of the fact that the over-burnt bricks have a compact structure and they are seems to be stronger than I Class bricks.

----- XXXXXX -----

## 1.6 Mortar

The term mortar is used to indicate a paste prepared by adding required amount of water to a mixture of binding material like cement or lime and fine aggregate like sand.

### Classification of Mortar

Mortars are classified based on the following factors:

1. **Bulk density:** According to the bulk density, mortars are classified as
  - a. **Heavy mortars:** The mortars whose bulk density is greater than equal to  $15\text{KN/m}^3$  are known as heavy mortars and they are prepared from heavy quartz or other sands.
  - b. **Light-weight mortars:** The mortars whose bulk density is less than  $15\text{KN/m}^3$  are known as light-weight mortars and they are prepared from light porous sands from pumice and other fine aggregates.
2. **Kind of binding material:** The kind of binding material for a mortar is selected based on working conditions, hardening temperature, moisture conditions etc. according to kind of binding material, mortars are classified as follows:
  - i. **Lime mortar:** In this type of mortar, lime is used as binding material. The lime may be fat lime or hydrated lime.

The fat lime shrinks to a great extent and hence it requires about 2 to 3 times its volume than sand. The lime should be soaked before use. This mortar is undesirable for water-logged areas or in damp situations.

For hydraulic lime, the proportion of lime to sand by volume is about 1:2 or so. This mortar should be consumed within one hour after mixing. It possesses more strength and can be used in damp situations.

The lime mortar has a high plasticity and it can be placed easily. It possesses good cohesiveness with other surfaces and shrinks very little. It is sufficiently durable, but it hardens slowly. It is generally used for lightly loaded structures above ground parts of building.
  - ii. **Surkhi mortar:** This type of mortar is prepared by using fully Surkhi instead of sand or by replacing half of sand in lime mortar. The powder of Surkhi should be fine enough to pass BIS No 9 sieve and the residue should not be more than 10% by weight.

The Surkhi mortar is used for ordinary masonry works of all kinds in foundation and super-structure. But it cannot be used for plastering or pointing works. Since Surkhi is likely to disintegrate after some time.
  - iii. **Cement mortar:** In this type of mortar, the cement is used as binding material. Depending upon the strength required and importance of work, the proportion of cement to sand by volume varies from 1:2 to 1:6 or more. It should be noted that Surkhi and cinder are not chemically inert substances and hence they cannot be used as adulterants with matrix as cement. Thus the sand only can be used to form cement mortar. The proportion of cement wrt sand should be determined with due regard to the specified durability and working

conditions. The cement mortar is used where a mortar of high-strength and water-resisting properties is required such as underground constructions, water saturated soils etc.

- iv. **Gauged mortars:** To improve the quality of lime mortar and to achieve early strength, the cement is sometimes added to it. This process is known as gauging. It makes the lime mortar economical, strong and dense. The usual proportion of cement to lime by volume is about 1:6 to 1:8. It is also known as the composite mortar or lime-cement mortar and it can also be formed by the combination of clay. This mortar may be used for bedding and for thick brick walls.
  - v. **Gypsum mortar:** These mortars are prepared from gypsum binding materials such as building gypsum and anhydrate binding materials.
3. **Nature of application:** According to the nature of application, the mortars are classified into two categories:
1. **Brick laying mortars:** The mortars for brick laying are intended to be used for brickwork and walls. Depending upon the working conditions and type of construction, the composition of masonry mortars with respect to the kind of binding material is decided.
  2. **Finishing mortars:** These mortars include common plastering work and mortars for developing architectural or ornamental effects. The cement or lime is generally used as binding material for ordinary plastering mortars. For decorative finishing, the mortars are composed of suitable materials with due consideration of mobility, water retention, resistance to atmospheric actions etc.
4. **Special mortars:** Following are the various types of special mortars which are used for certain conditions:
1. **Fire resistant mortars:** The mortar is prepared by adding aluminous cement to the fine crushed powder of fire bricks. The usual proportion is 1 part of aluminous cement to 2 parts of powder of fire bricks. This mortar is fire resistant and it is therefore used with fire bricks for lining furnaces, fire places, ovens etc.
  2. **Light-weight mortars:** This mortar is prepared by adding materials such as sawdust, wood powder etc., to the lime mortar or cement mortar. Other materials which may be added are asbestos fibers, jute fibers, coir etc. This mortar is used in the sound-proof and heat-proof constructions.
  3. **Packing mortars:** To pack oil wells, special mortars possessing the properties of high homogeneity, water-resistance, pre-determined setting time, ability to form solid water-proof plugs in cracks and voids of rocks, resistance to sub-soil water pressure etc., have to be formed. The varieties of packing mortars include cement-sand, cement-loam, and cement-sand-loam. The composition of packing mortar is decided by taking into consideration of hydro-geologic conditions, packing methods and type of timbering.
  4. **Sound absorbing mortars:** To reduce the noise level, the sound absorbing plaster is formed with the help of sound absorbing mortars. The bulk density of such a mortar varies from 6 to 12 KN/m<sup>3</sup> and the binding materials employed in its composition may be



Portland cement, lime, gypsum, slag etc. The aggregates are selected from light-weight porous materials such as pumice, cinders etc.

5. **X-ray shielding mortars:** This type of mortars is used for providing the plastering coat to walls and ceiling of x-ray cabinets. It is heavy type of mortar with bulk density over  $22 \text{ KN/m}^3$ . The aggregates are obtained from heavy rock and suitable admixtures are added to enhance the protective property of such a mortar.

### Properties of good mortar

The important properties of a good mortar mix are mobility, placeability and water retention.

- ❖ The term mobility is used to indicate the consistency of mortar mix which may range from stiff to fluid. The mobility of mortar mix depends on the composition of mortar and the mortar mixes to be used for masonry work, finishing work etc., are made sufficiently mobile.
- ❖ The placeability or the ease with which the mortar mix can be placed with minimum cost in a thin and uniform layer over the surface depends on the mobility of the mortar. The placeability of the mortar mix should be such that a strong bond should be developed with the surface of the bed.
- ❖ A good mortar mix should possess the ability of retaining adequate humidity during transportation and laying over the porous bed. If water retention power of the mortar mix is low, it separates into layers during transportation and when it comes into contact with porous bed such as brick, wood etc., it gives away its water to the surface. Thus the mortar becomes poor in amount of water and the remaining water proves to be insufficient for its hardening. Hence the required strength of mortar will not be achieved with such a mortar mix.

### Following are the properties of good mortar

1. It should be capable of developing good adhesion with the building units such as bricks, stones etc.
2. It should be capable of developing the designed stresses.
3. It should be capable of resisting penetration of rain water.
4. It should be cheap.
5. It should be durable.
6. It should be easily workable.

----- XXXXXX -----

## 1.7 Timber

### Introduction

The word timber is derived from an old English word “timbrian” which means to build. The timber thus denotes wood which is suitable for building or carpentry or various other engineering purposes and it is applied to the trees measuring not less than 600mm in girth or circumference of the trunk.

Following are the three terms to be noted in connection with the timber:

- **Converted Timber:** This indicates timber which is sawn and cut into suitable commercially sizes
- **Rough timber:** This indicates timber which is obtained after felling a tree.
- **Standing timber:** This indicates timber contained in living tree.

The timber or wood as a building material possesses a number of valuable properties such as low heat conductivity, lower bulk density, relatively high strength. However it has also its own drawbacks such as susceptibility to decay and inflammability. These drawbacks can be overcome by adopting new wood processing techniques.

### Classification of trees

For the engineering purposes, the trees are classified according to their mode of growth.

1. **Exogenous trees:** These trees increase in bulk by growing outwards and distinct consecutive rings are formed in the horizontal section of tree. These rings are known as annual rings because, one such ring is added every year & these rings are useful in predicting the age of the tree.
  - a. **Conifers trees:** The conifers are also known as evergreen trees and leaves of these trees do not fall till new ones are grown. As these trees bear cone-shaped fruits, they are given the name conifers. These trees yield soft woods which are generally light colored, light in weight and weak. They show distinct annual rings. The common examples are pine, chir etc.
  - b. **Deciduous trees:** These types of trees are also known as broad-leaf trees and leaves of these trees fall in autumn and new one appear in spring season. These trees yield hard woods which are closely grained, strong, heavy, dark colored, durable and they do not show distinct annual rings. The common examples are oak, sal and teak.
2. **Endogenous trees:** These trees grow inwards. The timber from these types of trees has limited engineering application. The common examples are bamboo, cane etc.

### Qualities of a good timber

1. **Appearance:** A freshly cut timber should exhibit hard and shining appearance.
2. **Color:** The color of timber should be preferably be dark. The light color indicates timber with low strength.
3. **Defects:** A good timber should be free from serious defects such as dead knots, flaws etc.
4. **Durability:** A good timber should be durable. It should be capable of resisting the actions of fungi insects, chemicals, physical agencies and mechanical agencies.
5. **Elasticity:** This is the property by which timber returns to its original shape when load causing its deformation is removed. This property would be essential when it is used for bows, sport goods etc.
6. **Fibres:** The timber should have straight fibers.
7. **Fire resistance:** The timber is a bad conductor of heat. A dense wood offers good resistance to the fire.
8. **Hardness:** a good timber should be hard i.e., it should offer resistance when being penetrated by others.
9. **Mechanical wear:** A good timber should not deteriorate easily due to mechanical wear or abrasion. This type of timber would be more employed where it is subjected totraffic.
10. **Shape:** A good timber should be capable of retaining its shape during the conversion or seasoning.
11. **Smell:** A good timber should have sweet smell. An unpleasant smell indicates decayed timber.
12. **Water permeability:** A good timber should have low water permeability which is measured by quantity of water filtered through the unit surface area of the wood specimen.

----- XXXXXX -----

### Aggregates

#### Introduction

Aggregates are defined as inert, granular and inorganic materials that normally consist of stone or stone like solids. Aggregates can be used alone (in road bases and various types of fill) or can be used with cementing materials (such as Portland cement or asphalt cement) to form composite materials or concrete.

Since aggregates constitutes about  $3/4^{\text{th}}$  of the volume of concrete, it contributes significantly to the structural performance of concrete especially strength, durability and volume stability. Aggregates are formed from natural sources by the process of weathering and abrasion or by artificially by crushing a large parent rocks.

### Classification of aggregates

Aggregates can be divided into several categories according to different criteria.

#### a) In accordance with size:

**Coarse aggregate:** if particle size is greater than 4.75mm are regarded as coarse aggregates

**Fine aggregates:** if particle size in between  $75\mu$  & 4.75mm are regarded as fine aggregates

#### b) In accordance with sources:

**Natural aggregates:** This kind of aggregates is taken from natural deposits without changing their nature during the process of production such as crushing and grinding. Some examples in this category are sand, crushed limestone and gravel.

**Manufactured aggregates:** This is a kind of man-made materials produced as main product or an industrial by-product. Some examples are blast furnace slag, lightweight aggregate (e.g. expanded perlite), and heavy weight aggregates (e.g. iron ore or crushed steel)

#### c) In accordance with unit weight:

**Light weight aggregates:** the unit weight of aggregates is less than  $1120\text{kg/m}^3$ . The corresponding concrete has a bulk density less than  $1800\text{kg/m}^3$ . (Cinder, blast-furnace slag, volcanic pumice).

**Normal aggregates:** The aggregates have unit weight of  $1520\text{-}1680\text{kg/m}^3$ . The concrete made with this type of aggregates has a bulk density of bulk density of  $2300\text{-}2400\text{kg/m}^3$ .

**Heavy weight aggregate:** The unit weight is greater than  $2100\text{kg/m}^3$ . The bulk density of the corresponding concrete is greater than  $3200\text{kg/m}^3$ . A typical example is magnesite limonite, a heavy iron ore. Heavy weight concrete is used in special structures such as radiation shields.

## 1.8 Fine Aggregates

### Grading of aggregates

- Particle size distribution of an aggregate is determined by sieve analysis is known as „grading of the aggregate“
- Aggregate comprises about 55% of the volume of mortar and about 85% of volume of concrete. Mortar contains aggregates of size 4.75mm and the concrete contains aggregates upto a max. size of 150mm.
- Strength of concrete is dependent upon water-cement ratio. One of the most important factors for producing workable concrete is good grading of aggregates.
- Grading of aggregates are of 3 types

**Good graded or well graded:** It implies that a given sample of aggregates contains all standard fractions such there will be minimum number of voids.

**Uniformly graded or poor graded:** It contains aggregate particles that are almost of the same size. This means that the particles pack together, leaving relatively large voids in the concrete.

**Gap graded:** It consists of aggregate particles in which some intermediate size particles are missing.

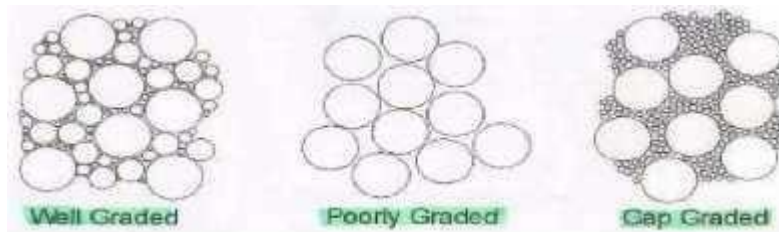

A sample of good grading of aggregate containing min. voids will require min. paste to fill up the voids in the aggregate and this will produce a higher strength, lower shrinkage and greater durability.

**Sieve:** It is a circular disc consists of wire mesh of square aperture.

**Sieve analysis:** This is the name given to the operation of dividing the given sample of aggregates into various fractions each consisting of particles of same size. The sieve analysis is conducted to determine the particle size distribution in a sample of aggregates which is also called as **Gradation**.

- The aggregates used for making concrete are normally of the maximum size 80 mm, 40 mm, 20 mm, 10 mm, 4.75 mm, 2.36 mm, 600 micron, 300 micron and 150 micron.
- The aggregate fractions from 80 mm to 4.75 mm are termed as coarse aggregate and those fractions from 4.75 mm to 150 micron are termed as fine aggregate.

Sieves are placed one above the other, maximum size is placed at the top and minimum size in the bottom. Sieving can be done either manually or by mechanically with sieve shaker. From the sieve analysis, the particle size distribution in a sample is found out; from this fineness modulus can be determined.

**Fineness Modulus:** It is a relative index which indicates the particles are either coarser or finer. The sum of cumulative percentage retained on the sieves divided by 100 gives fineness modulus of given sample of aggregates.

For sand the following limits are taken as guidelines

**Fine sand** → 2.2 – 2.6

**Medium sand** → 2.6 – 2.9

**Coarse sand** → 2.9 – 3.2

### Tests on Fine aggregates

#### Specific Gravity:

- The specific gravity of an aggregate is the ratio of the mass of solid in a given volume of sample to the mass of equal volume water at the same temperature.
- They are of two types 1) absolute specific gravity and 2) apparent specific gravity.
- Absolute specific gravity is defined as ratio of mass of solid to the mass of an equal void-free volume of water. If the volume of aggregate includes the voids, then resulting specific gravity is called apparent specific gravity.
- Average specific gravity of the rocks varies from 2.6 to 2.8.
- It's required for calculation of the quantity of aggregate for a given volume of concrete.

#### 1) Determination of Specific gravity of fine aggregates by Pycnometer method

##### Procedure

1. Find the weight an empty Pycnometer with stopper. Let it be  $W_1$  gms.
2. Take about  $1/3^{\text{rd}}$  the volume of Pycnometer full of sand. Find the weight of Pycnometer with sand and let it be  $W_2$  gms.
3. Now fill the Pycnometer to its half with water so as to submerge the sand inside. Allow the entrapped air from sand to escape. Then fill the Pycnometer with water. Replace the stopper and find the total weight Pycnometer with its constituents and let it be  $W_3$  gms.
4. Remove the constituents from the Pycnometer and clean it. Fill completely with water and replace the stopper. Find the weight with water and let it be  $W_4$  gms.

$$\text{Specific gravity} = \frac{(W_2 - W_1)}{(W_3 - W_1) - (W_4 - W_1)}$$

## 2) Bulking of sand

**Bulking can be defined as that property of sand by virtue of which it expands in volume when it is wet.** This is because, when water is added to the sand, each particle will be coated by a film of water and keeps far apart from each other due to surface tension. Hence it is necessary to take the moisture content into account while measuring the sand by volume for proportioning concrete. Bulking increases with the increase in water content up to 4% by weight and then decreases. Bulking also increases with fineness of particles.

### Procedure

1. Take about 300gms of dry sand and pour it into a measuring jar. Note down the initial volume of sand.
2. Transfer the sand into a non absorbent pan and add 1% (by weight of sand) of water. Mix the sand thoroughly with a glass rod so that a uniform color is obtained.
3. Then pour the wet sand into the measuring jar and note down the rise in volume.
4. Again transfer the sand into the pan and add another 1% of water by weight of sand. Mix thoroughly and pour back into the jar and note down the new volume.
5. Repeat this process by increasing the water content at the rate of 1% up to 3, 4, 5, 6% and so on until the volume starts decreasing.
6. Plot a graph of % increase in volume V/S % of water added.

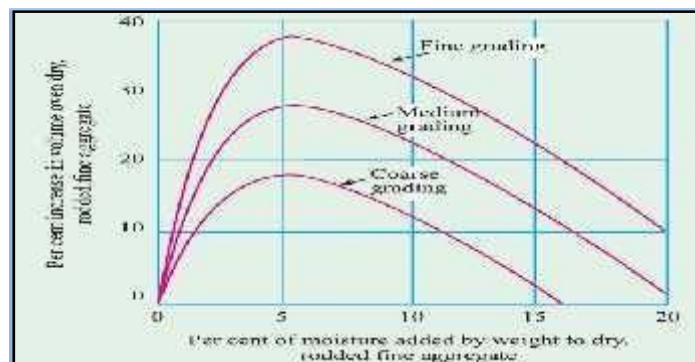

## 3) Measurement of moisture content for fine aggregate

**Moisture content means free water held on the surface of aggregate which includes the absorbed water and the water held in the interior portion of the aggregate.**

1. **Drying method:** The drying method is carried out in a oven and the loss in weight before and after drying will give the moisture content of the aggregate. If drying is done at high temperature for long time, the loss in weight will include not only the surface water but also

some absorbed water. A fairly quick result can be obtained by heating the aggregate in an open pan and the process can be speed up by pouring inflammable liquid like acetone on the aggregate and igniting it.

2. **Displacement method:** In the laboratory, the moisture content of aggregate can be determined by means of Pycnometer. The principle made use of is that specific gravity of normal aggregate is higher than that of water and that a given weight of wet aggregate will occupy a greater volume than the same weight of dry aggregate. By knowing the specific gravity of dry aggregate, specific gravity of wet aggregate can be calculated. From the difference between specific gravity of wet and dry aggregates, the moisture content of the aggregate can be calculated.
3. **Calcium Carbide method:** A quick and reasonably accurate method of determining the moisture of fine aggregate is to mix with excess amount of calcium carbide in a strong air-tight vessel fitted with pressure gas. Calcium carbide reacts with surface moisture in the aggregate to produce acetylene gas. The pressure of acetylene gas generated depends upon the moisture content of the aggregates. The pressure gauge is calibrated by taking a measured quantity of aggregate of known moisture content and then such a calibrated pressure gauge could be used to read the moisture content of aggregate directly. The method is often used to find out the moisture content of fine aggregate at the site of work. The equipment consists of a small balance, a standard scoop and container fixed with dial gauge. The procedure is as follows; weigh 6gms of wet sand and pour it into the container. Take one scoop full of calcium carbide powder and put it into the container. Close the lid of the container and shake it rigorously. Calcium carbide reacts with surface moisture and produces acetylene gas, the pressure of which drives the indicator needle on the pressure gauge. The pressure gauge is so calibrated, that it gives directly the percentage of moisture present in the sample. The whole job takes only less than 5mins and as such, this test can be done at very close intervals of time at the site of work.
4. **Electrical meter method:** Recently electrical meters have been developed to measure instantaneous or continuous reading of the moisture content of the aggregate. The principle that the resistance gets changed with the change in moisture content of the aggregate has been made use in some sophisticated batching plant. Electrical meters are used to find out the moisture content and also to regulate the quantity of water to be added to the continuous mixture.
5. **Automatic measurement:** In modern batching plants surface moisture in aggregates is automatically recorded by means of some kind of sensor arrangements. The arrangement is made in such a way that, the quantity of free water going with aggregate is automatically recorded and simultaneously that much quantity of water is reduced. This sophisticated method results in an accuracy of  $\pm 0.2$  to  $0.6\%$ .



**Alternatives to river sand**

Sand is a vital ingredient in making two most used construction materials viz. Cement Concrete and mortar. Traditionally River sand, which is formed by natural weathering of rocks over many years, is preferred as fine aggregate. The economic development fuelling the growth of infrastructure and housing generates huge demand for building materials like sand. The indiscriminate mining of sand from riverbeds is posing a serious threat to environment such as erosion of riverbed and banks, triggering landslides, loss of vegetation on the bank of rivers, lowering the ground water table etc. Demand for sand is increasing day by day and at the same time mining threats cannot be ignored. Hence, sand mining from riverbeds is being restricted or banned by the authorities like National Green Tribunal, State Environmental Impact Assessment Authority and Pollution Control Board

**Some of the Alternatives to River sand**

- Manufacture Sand
- Processes Quarry dust
- Processed Crushed rock fines
- Offshore Sand
- Processed glass
- Aluminum saw mill waste
- Granite fines slurry
- Washed soil (filtered sand)
- Fly ash (bottom ash/ pond ash)
- Slag sand
- Copper Slag sand
- Construction Demolition waste.

notes4free.in

**Manufacture Sand**

Manufactured sand is crushed fine aggregate produced from a source material and designed for use in concrete or for other specific products. Only source materials with suitable strength, durability and shape characteristics should be used.

## 1.9 Coarse Aggregates

### Importance of size, shape and surface texture of aggregates on workability and strength

- **Size of aggregate:** Bigger the size of particles less will be the surface area and hence less amount of water is required and also less cement paste required for lubricating the surfaces of aggregates. So bigger the size, gives higher workability.
- **Shape of aggregate:** Angular, elongated or flaky aggregates make the concrete very harsh when compared to rounded or cubical aggregates. Contribution to better workability of rounded aggregate will come from the fact that for a given volume or weight. It will have a less surface area and less voids. Not only is that being in rounded in shape, the frictional resistance between the aggregates also reduced. Hence the workability will be more in case of rounded than compared to flaky aggregates. Hence the strength will be more by using rounded or cubical aggregates.
- **Surface texture:** Surface texture is the property, the measure of which depends upon the relative degree to which particle surface are polished or dull, smooth or rough. Surface texture depends on hardness, grain size, pore structure and structure of the rock.

Total surface area of rough texture aggregate is more than that of surface area of smooth rounded aggregates of same volume. Rough textured aggregates will show poor workability and smooth textured aggregates will give better workability because of lesser frictional resistance of inner surface particle.

### Testing of Coarse Aggregates

#### ➤ Test for determination of flakiness index

An aggregate having least dimension less than  $\frac{3}{5}$ <sup>th</sup> of mean dimension is termed as flaky. This test is not applicable to aggregates less than 6.3mm. This test is conducted by using a metal thickness gauge. A sufficient quality of aggregates is taken ie, a minimum of 200 pieces of any fraction to be tested. Each fraction is gauged in terms of thickness on metal gauge. The total amount of aggregate pieces passing through each gauge is weighed accurately. **Flakiness index is calculated by taking the ratio of total weight of materials passing through the various thickness gauges to the total weight of aggregate sample taken.**

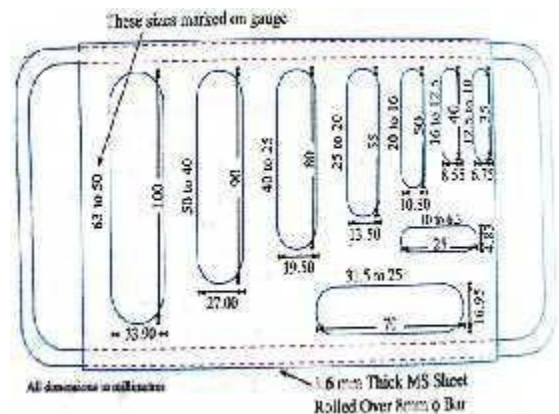

#### ➤ Test for determination of elongation index

The elongation index of an aggregate is the particle having largest dimension (length) is greater than  $\frac{9}{5}$ <sup>th</sup> of mean dimension. The elongation index is not applicable to sizes lesser than 6.3mm. This test is conducted by using metal length gauge. A sufficient quantity of

aggregate is taken to provide a minimum number of pieces of 200 of any fraction to be tested. Each fraction shall be gauged individually for the length on metal gauge. The amount retained by the gauge length shall be weighed to an accuracy of 0.1% of the weight of sample taken. **The elongation index is calculated in percentage by taking the ratio of total weight of materials retained on various length gauges to the total weight of aggregate sample taken.**

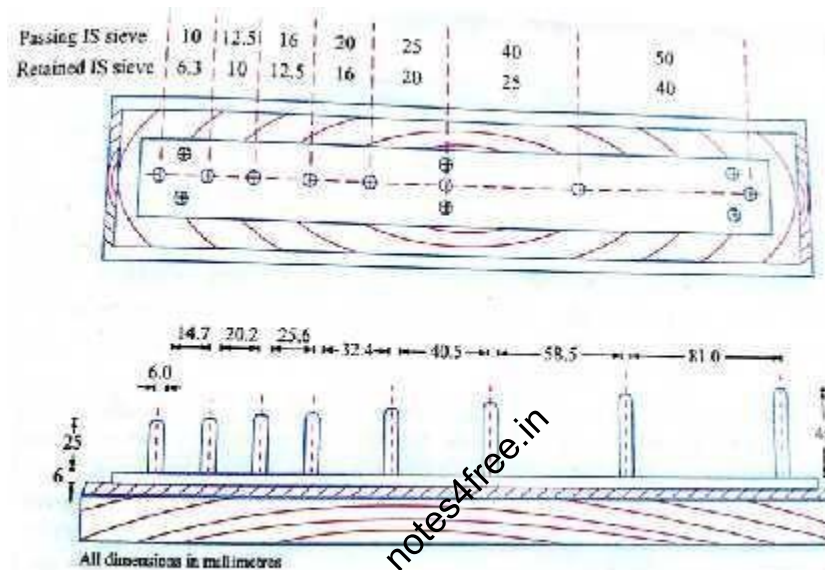

Fig. 3.10. Length Gauge.

➤ **Test to determine Specific Gravity of coarse aggregate by wire basket method**

1. Take about 5kg of coarse aggregates passing through 4.75mm sieve.
2. Wash thoroughly to remove dust, dry to constant mass at a temperature of  $105 \pm 5^\circ\text{C}$ .
3. Immerse the sample in water in water at 22 to  $32^\circ\text{C}$  for a period of  $24 \pm 1/2$  hours (30min in practice).
4. Remove the aggregates from water & roll the same in a large piece of an absorbent cloth until all visible films of water are removed, although the surface of the particles will still appears to be damp.
5. Now, weigh 3kg of this sample in the in the saturated dry condition and note down the mass as  $W_1\text{gm}$ .
6. Place the weighed aggregate immediately in the wire basket & dip it water. Weigh this bucket with aggregates, keeping it in water with the help of a balance. Note down the mass as  $W_3\text{ gm}$ .

7. Note down the weight of suspended empty wire basket in water without aggregates and note down the mass as  $W_2$  gm.
8. Dry the sample to the constant weight at the temperature of 100 to 110°C for  $24 \pm 1/2$  hours.
9. Cool to room temperature and weigh it & note down the mass as  $W_4$  gm.
10. Calculate specific gravity and repeat the procedure for fresh sample of aggregates.

Weight of oven dry aggregate (C) =  $W_4$  gm.

Weight of saturated surface dry aggregate (B) =  $W_3$  gm.

Weight of basket & aggregates in water ( $A_1$ ) =  $W_2$  gm.

Weight of empty basket submerged in water ( $A_2$ ) =  $W_1$  gm.

$$\text{Actual Specific gravity} = \frac{C}{B-A}$$

$$\text{Apparent specific gravity} = \frac{C}{C-A}$$

$$\text{Water absorption} = 100 \times \frac{B-C}{C}$$

notes4free.in

Where A = weight of saturated aggregate in water =  $A_1 - A_2$ .

### Testing of mechanical properties of aggregates

#### A. Test for determination of aggregate crushing value

The aggregate crushing value gives a relative measure of the resistance of an aggregate to crushing under a gradually applied compressive load.

Apparatus required for this test are as follows

1. Steel cylinder (dia-15.2cm, height-14cm)
2. Cylindrical measure (dia-11.5cm, height-18cm)
3. Steel tamping rod (dia-1.6cm, height- 40 to 60cm)
4. Balance
5. Compression testing machine

#### Procedure

1. Oven dry aggregate passing 12.5mm IS sieve and retained on 10mm IS sieve is selected for the test.

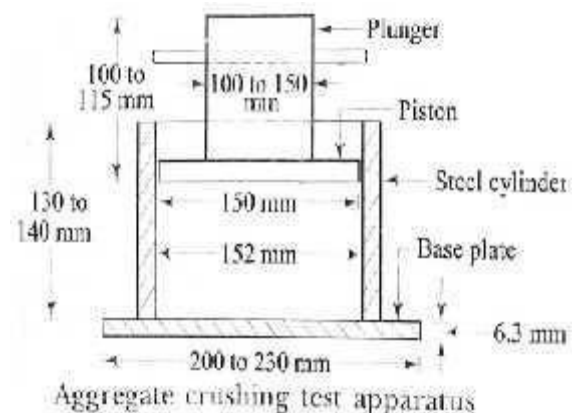

2. The sample aggregates in filled three layers and each layer being tamped 25 blows by rounded end of the tamping rod.
3. After tamping the third layer, the top surface is leveled using the tamping rod as straight edge. The test sample weight is taken as  $W_1$  gms.
4. The cylinder of the test apparatus is placed in position on the base plate and the test sample is transferred into the cylinder in three layers and each layer is tamped with 25blows.
5. The surface of the aggregate is leveled and the plunger inserted.
6. The cylinder with the test sample and plunger in position is placed on CTM.
7. Load is then applied through the plunger at a uniform rate of 4tones/min until the total load of 40tones and then the load is released.
9. Aggregates including the crushed portion are removed from the cylinder and sieved on a 2.36mm IS sieve, the material which passes through this sieve is collected and taken  $W_2$  gms.

$$\text{Aggregate crushing value} = \frac{W_2}{W_1} \times 100$$

**Note:** According to Indian road congress & IS 1 has specified that aggregate crushing value of the coarse aggregate used for cement concrete pavements should not exceed 30% and used for concrete other than wearing surface should not exceed 45%.

### B. To determine the aggregate impact value

**The aggregate impact value gives the relative measure of the resistance of an aggregate to sudden shock or impact.**

Apparatus required for the experiment are as follows

1. Impact testing machine
2. Cylindrical measure
3. Tamping rod
4. Balance

### Procedure

1. Oven dry aggregate passing through 12.5mm IS sieve and retained in 10mm IS sieve are selected for the test.
2. The cylindrical measure is filled by the sample aggregates in three layers and each layer being tamped by 25blows with rounded end of the tamping rod.

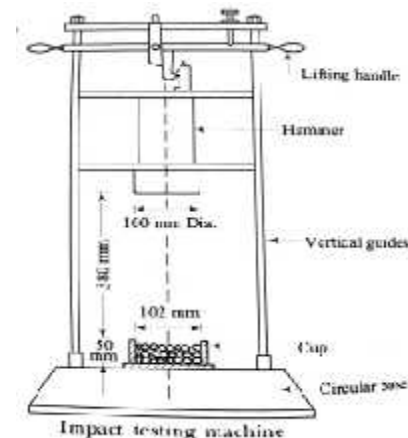

3. After tamping the third layer, the top surface is leveled using the tamping rod as straight edge. The test sample weight is taken as  $W_1$  gms.
4. The cup of the test apparatus is placed in position on the base plate and test sample is transferred to the cup in a single layer and being tamped 25 blows and top surface is leveled.
5. The hammer is raised until its lower face is 38cm above the upper surface of the aggregate in the cup, and allowed to fall freely on aggregate for 15 times at an interval not more than 2 seconds and not less than 1second.
6. The crushed aggregate is then removed from the cup and the whole sample is sieved on 2.36mm IS sieve, the material which passes this sieve is collected and taken  $W_2$  gms.

**Aggregate impact value** =  $\frac{W_2}{W_1} \times 100$

**Note: According to IS specification, the aggregate impact value**

- < 10% → exceptionally strong
- 10 – 20% → strong
- 20 – 30% → satisfactory for road surfacing
- > 30% → weak for road surfacing

**Recommended aggregate impact value for different types of pavements**

No.	Type of pavement surfaces	Max. aggregate impact value (percentage)
1	Bituminous surface dressing; penetration macadam; cement concrete wearing course	30
2	Bitumen bound macadam	35
3	Cement concrete base course	45

**Test for the determination of aggregate abrasion value**

Apparatus required for the experiment are as follows

1. Los-Angeles machine
2. Steel balls (dia - 48cm, weight - 390 to 445g)
3. Balance
4. Sieves

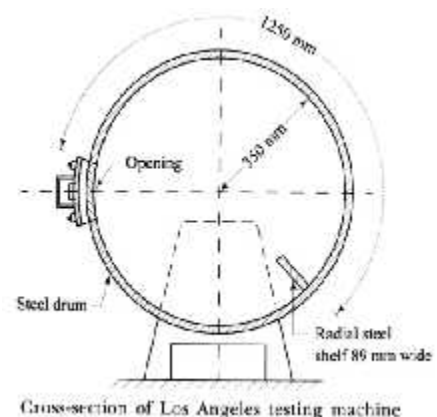

**Procedure**

1. Clean dry aggregate, confirming to any one of the grading A to G is used for the test. Aggregate weighing 5kg for grading A, B, C or D and 10kg for grading E and for G may be taken as test specimen and placed in the cylinder and is noted as  $W_1$  gms.
2. The abrasive charge is also chosen depending upon the aggregate and is placed in the cylinder of the machine; the cover is then fixed dust tight.
3. The machine is rotated for 500 revolutions for grading A, B, C and D & for grading E, F and G it shall be rotated for 1000 revolutions.
4. After the desired number of revolutions, machine is stopped and the material is discharged from the machine taking care to take out entire stone dust.
5. Using 1.7mm IS sieve the material is sieved and the coarser material is retained on the sieve is taken as  $W_2$  gms.

**Percentage wear =  $\frac{W_2}{W_1} \times 100$**

**Specifications for Los-Angeles test**

No.	Sieve size		Weight (in gms) and grading of test samples						
	Passing on mm	Retained on mm	A	B	C	D	E	F	G
1	80	63	-	-	-	-	2500	-	-
2	63	50	-	-	-	-	2500	-	-
3	50	40	-	-	-	-	5000	5000	-
4	40	25	1250	-	-	-	-	5000	5000
5	25	20	1250	-	-	-	-	-	-
6	20	12.5	1250	2500	-	-	-	-	-
7	12.5	10	1250	2500	-	-	-	-	-
8	10	6.3	-	-	2500	-	-	-	-
9	6.3	4.75	-	-	2500	-	-	-	-
10	4.75	2.36	-	-	-	5000	-	-	--
<b>Number of spheres to be used</b>			12	11	8	6	12	12	12
<b>Number of revolutions</b>			500				1000		

**Maximum allowable Los-Angeles abrasion values**

No.	Type of surface	Maximum abrasion values
1	W.B.M subsurface course	60
2	W.B.M base course with bituminous surfacing	50
3	W.B.M surface course	40
4	Cement concrete surface course	35
5	Bituminous / Asphalt concrete surface course	30

## 1.10 Questions

1. What is a stone?
2. What is timber?
3. Define aggregates
4. Define fine aggregates
5. Define coarse aggregate
6. Define cement
7. Define concrete

## 1.11 Outcome

Gives Knowledge about different building materials used for construction of buildings.

## 1.12 Future Study

<http://nptel.ac.in/courses/105102088/>

notes4free.in



## Module – 2

### Foundation & Masonry

#### Structure

2.1.1 Introduction

2.1.2 Objectives

2.1.3 Functions of Foundation:

2.1.4 Requirements of good Foundation

2.1.5 Bearing capacity of soils

2.1.6 Types of foundations

2.1.7 Masonry

2.1.8 Types of walls

2.1.9 Questions

2.1.10 Outcomes

2.1.11 Future Study

notes4free.in

## Foundation

### 2.1.1 Introduction

Building is an assemblage of various structural components like beams, columns, slabs and footings which resists deformation caused due to external loads. Therefore buildings are means of transferring forces and moments.

Building consists of two parts

- Substructure: The structural components which are constructed below ground level are called substructures.
- Superstructure: The structural components which are constructed above ground level are called superstructures.

**Foundation** is a substructure which transmits the load of the superstructure to the underlying soil. It is the most critical part of building which is to be designed carefully. The soil on which foundation rests is called foundation bed.

### 2.1.2 Objectives

- To study the basic parts of a building
- To study the requirements of good foundations
- To gain the knowledge on types of foundations

### 2.1.3 Functions of foundation

1. To distribute the total load of the building evenly over large area.
2. To support the structure.
3. To give enough stability to the structure against disturbing forces like rain, wind, earthquakes etc.
4. To provide a level surface for concreting or masonry works.
5. To take structure deep into the soil and thus provides enough stability.
6. To provide structural safety against scouring and undermining due to animals and flood water.
7. To prevent or minimize cracks due to movement of moisture in case of weak or poor soils.

### 2.1.4 Requirements of foundations

1. **Location:** The foundation should be located in such a way that it is able to resist any unexpected future influence which may adversely affect its future performance.

2. **Stability:** The foundation structure should be constructed to sustain the dead and imposed loads and transmits these loads to subsoil in such a way that the pressure on the soil should not cause any settlements and should be provide stability to the structure.
3. **Settlements:** Foundation base should be rigid so that differential settlements are minimized.
4. Foundation should be taken sufficiently deep to protect the building from damage caused due to swelling or shrinkage of subsoil.

### **Causes of failure of good foundation**

1. Non-uniform settlement of subsoil and masonry
2. Alternative swelling and shrinkage of subsoil.
3. Action of weathering agencies like sun, rain, wind, and earthquake forces etc.
4. Root trees and shrubs which penetrate into the soil which has more affinity towards water which may leads to the failure of the foundation.

### **Site Investigation**

Site investigation or sub-surface exploration is done in order to obtain the information about soil condition at the site of proposed construction. This is very important for big engineering projects based on which the design and construction techniques are planned.

Site investigation of soil involves 3 stages

- **Reconnaissance survey:** This is the first step in the site investigation. It includes a visit to the site and to study the maps in order to know the geographical features of the site based on which the exploration methods are decided.
- **Preliminary investigation:** This is done in order to determine nature of soil, depth of bed rock, depth of groundwater table by excavating small test pits in the site.
- **Detailed investigation:** This is to determine the engineering properties of soil such as SBC (Safe Bearing Capacity), permeability, shrinkage & swelling by conducting laboratory test on soil collected from the test pit.

### **Preliminary investigation**

The following are the information's collected during preliminary investigation are as follows:

1. Behavior of ground due to variation in depth of water table
2. Disposal of storm water at site.
3. Nature of soil by visual examination
4. Movement of ground due to any reasons etc.

### **Purpose of site exploration**

1. To fix the value of SBC of soil.

2. To select an economical & safe type of foundation.
3. To fix the depth up to which the foundation must be taken into the ground.
4. To predict the likely settlements of soil and certain allowance are made in designing the foundation.
5. To select the suitable construction technique.

### Methods of exploration

Following are the various methods of site exploration.

1. **Test pits:** A square pit, known as trial pit or a test pit with side about 1.5m is excavated up to a depth at which sufficiently hard soil is available. The various strata of the soil can be inspected, studied and classified along its depth of formation. This method is useful when the depth of foundation is restricted to 1.5m.

Following are the points to be noted.

- i) A sufficient number of pits should be dug to know the variation of ground.
- ii) The test pits should be examined after excavation of test pit completed.

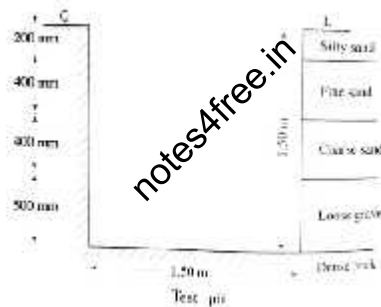

2. **Probing:** the probing consists of driving either a hollow tube or a steel rod into the ground. A hollow tube which has diameter various about 35 to 50mm is taken. The hollow tube consists of slit of 3mm thick and 600mm long at the bottom. The tube is driven into the ground for 300mm at once and then it is withdraw back. The material which is caught in the slit is collected and examined.

In other case, a solid rod made of steel or iron is driven into the ground for a reasonable depth and the material which is staked at the pointed end is collected and examined.

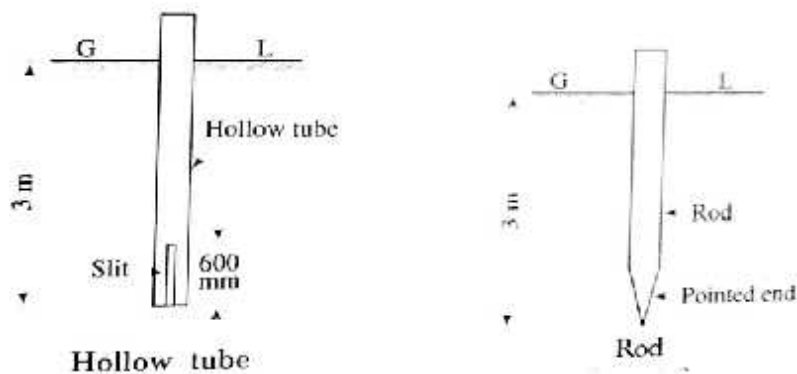

3. **Auger boring:** An auger may be of post-hole, screw or shell type. They all work in the same way. Shell auger consists of hollow tube of diameter about 75mm to 100mm. the tube is provided with a cutting edge at the bottom which facilitates the tube to pierce into the ground. A slit is provided over a length of about 600 to 900mm is provided at the bottom to catch up the material and the whole length of the hollow tube is about 1.5m. At the top of the hollow tube threads are provide in order to extend the length of the tube in case of deep excavation. The tube is driven into the ground like a screw and withdrawn back and the material stuck up in the slit is collected and examined.

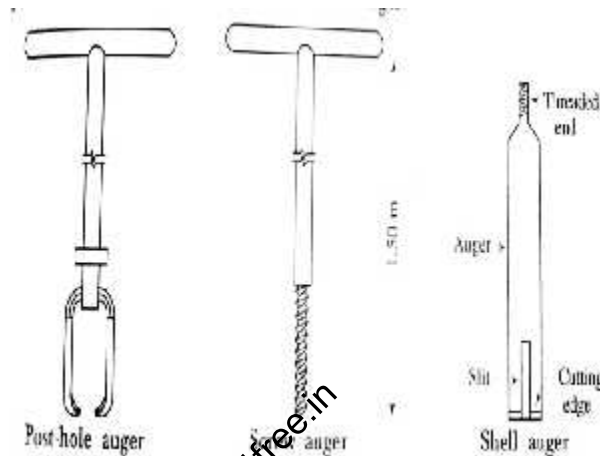

4. **Wash boring:** The wash boring is the term used to denote a method in which a casing is driven in to the ground and the material inside the casing is washed out and brought to the surface for examination.

The process of wash boring consists of driving a inner tube of diameter 25 to 50mm inside an outer tube of diameter 100 to 150mm. the simultaneously forced with driving the tube under pressure through the inner tube. This facilitates easy driving of tube and makes the soil loose and flows through the annular space. The quantity of water required is about 100 to 300 liters per min under a pressure of  $36.86 \text{ KN/m}^2$ . The process will be continued till hard ground is available. The washed material will be collected in a tank and later it is examined.

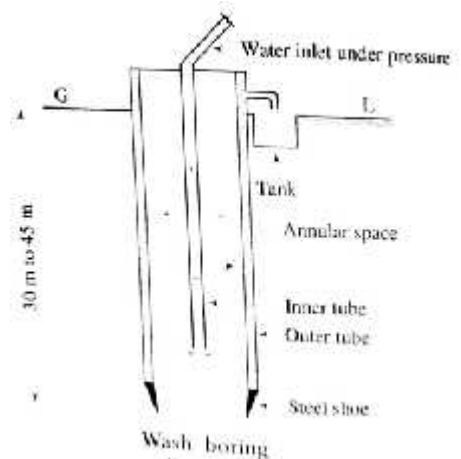

5. **Sub-surface soundings:** In this method, the resistance of the soil with the depth is measured by means of a tool known as the penetrometer. The penetrometer consists of sampling spoon, a cone or tool of other shape.
- The penetrometer is driven into the ground with the help of blows from a 650N weight falling from a height of 750mm.
  - The number of blows required to drive the penetrometer for a depth of 300mm is measured. It is known as standard penetration resistance.

(iii) The value of SPT of soil at different depth is determined.

6. **Test piles:** Sometimes the test piles are driven into the ground to obtain the information of the solid strata. With the help of this process, it is not possible to know definitely the kinds of soil strata through which the test piles pass, as the material is not available for examination. But the factors such as resistance of soil to driving of piles, load bearing data and any other available local information serves as guide.
7. **Deep boring:** It becomes essential to carry out deep boring for big important engineering structures such as dams. In such structures, in addition to the stability of the superstructure, the importance is to be given to various other factors such as non-leakage of the stored water, seepage through porous strata etc.

The machines used for deep boring are as follows:

- a. **Percussion boring machine:** In this process, the heavy cutting tool is dropped into the ground by means of a series of blows. The broken material is brought to the ground by adding water into the core and then the paste is lifted to the ground. The material thus obtained is made dry and it is then examined. The percussion boring machine is very much useful for hard material like rock.
  - b. **Core or rotary drilling machine:** In this process, a hollow tube is driven by rotary motion which cuts a solid core. The water is used to facilitate the cutting process. The machine can be used either for soft or hard material. When the tube passes through the soft material, no core is obtained and the slurry material formed has to be pumped out after the tube is withdrawn. When the tube passes through the hard material, the core is formed and this has to be cut at the bottom and lifted up. This is done by pouring sand at the inner side i.e., between the core and the inner surface of the tube and then the tube is slightly rotated. The core is collected and examined.
8. **Geo-physical method:** In favorable circumstances, the geo-physical method is adopted to know the nature of soil strata. These methods are used when the exploration depth is not specific and speed of investigation is of primary importance. These methods are mainly adopted to ascertain the depths at which useful minerals and oils are available. The two most commonly adopted methods for civil engineering purposes are as follows.
    - i) **Electrical resistivity method:** In this method four electrodes are driven in the ground at equal distance apart and in a straight line. The distance between two electrodes indicates the depth of excavation or depth up to which the ground resistance need to be measured. An electrical current is then passed between the two outer electrodes and the potential drop between the two inner electrodes is measured with the help of potentiometer. The mean resistivity is then calculated by the following equation.

$$\rho = 2 \pi D E/I$$

Where  $\rho$  = mean resistivity (ohm-cm)

D = distance between electrodes

E = Potential drop between inner electrode (V)

I = Current flowing between outer electrode (A)

This method is based on the principle that each soil has different electrical resistivity depending upon its water content, compaction and composition. For example saturated soils will have lower electrical resistivity as compared to the loose dry gravel or rock.

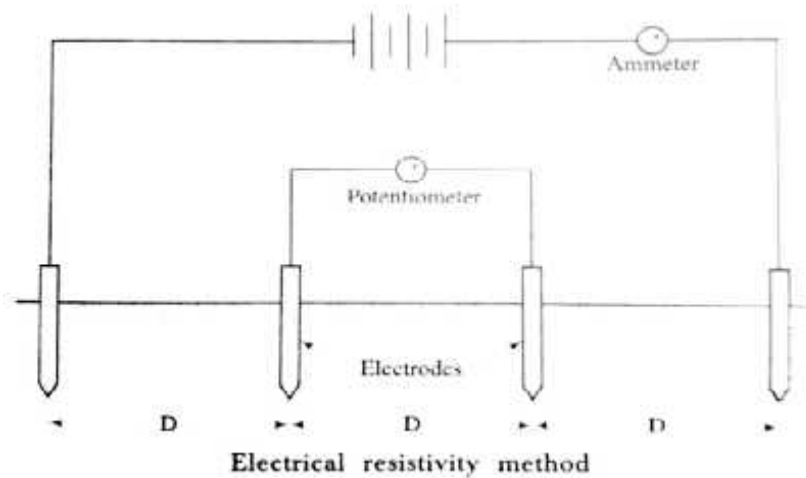

ii) **Seismic refraction method:** This method is based on the principle that, the vibrations caused in the ground by artificial explosions travel faster in rock than in soil. This is due to the fact that the velocity of sound waves is different in different medium.

The shock waves are developed into the soil at ground level or at a certain depth below it, either by exploding small charge in the soil or by striking a plate on the soil with a hammer. The shock waves so produced travel down in the subsoil strata and get refracted after striking a hard rock surface below. These refracted rays are picked up and their times of travel are recorded in the instruments known as geophones.

A number of geophones are arranged along a line. Some of the waves known as direct or primary waves are first picked up by geophones. The other waves which travel down through the soil get refracted after striking a hard rock surface below.

The depth of various strata can be evaluated by knowing the time of travel of the primary and refracted rays and then preparing the distance-time graphs.

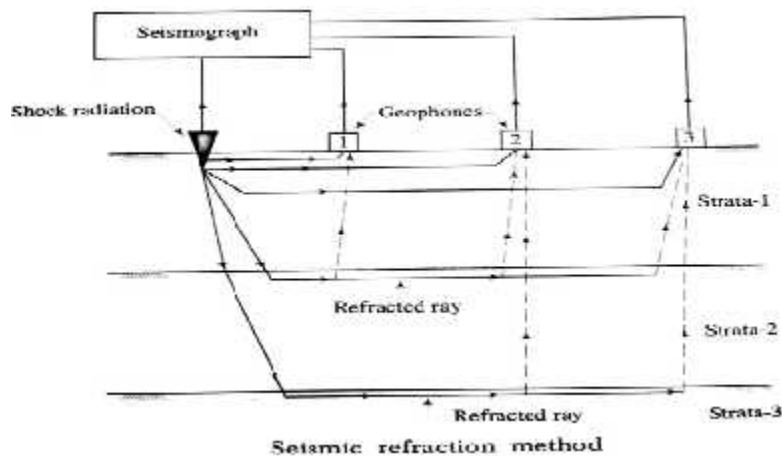

### 2.1.5 Safe Bearing Capacity

#### Terminologies

- Bearing Capacity: The maximum load per unit area the soil can resist is known as bearing capacity.
- Gross Pressure intensity ( $q$ ): It is the total pressure intensity caused due to the load from super-structure and overburden pressure (weight of overlying soil).
- Net Pressure intensity ( $q_n$ ):  $q - (\gamma * D)$
- Ultimate bearing capacity ( $q_f$ ): The minimum load at which the soil undergoes shear failure.
- Net ultimate bearing capacity ( $q_{nf}$ ):  $q_f - (\gamma * D)$
- Safe Bearing capacity ( $q_s$ ): The maximum load at which the soil takes the risk of shear failure.
- Net safe bearing capacity ( $q_{ns}$ ):  $q_s - (\gamma * D)$

#### Methods for determining the bearing capacity of soil

1. **Method of loading:** The materials required for the test are as follows:

- Steel square plate: The size of the plate usually varies from 3000 to 7500mm<sup>2</sup> in area and should have minimum thickness of 25mm.
- Platform: This is usually made of a wooden table having four legs and a top plank board. The two blocks of wooden beams are placed on the plank board in a well balanced position.
- Wooden pegs: The pegs are driven with 50mm projection above the ground level. They are used to maintain level of bench mark.
- Dumpy level with staff: This is a levelling instrument used to note the settlement of the steel plate.
- Rolled steel sections: They are available in standard size and weights. They are arranged in two layers over a platform to take the load of sand bags.
- Sand bags: They are used for incremental loading.

#### Procedure

- A square pit of required size is excavated up to required depth. The side of the pit is equal to 5 times the side of the steel plate. At the centre, a square hole is dug of size equal to side of the steel plate. The bottom of the hole should correspond to the foundation level and the ratio of breadth to depth of pit should be made equal to ratio of depth to breadth of hole.
- The bottom of the hole is made leveled by scraping and it is well protected against the disturbing forces before and during the test.

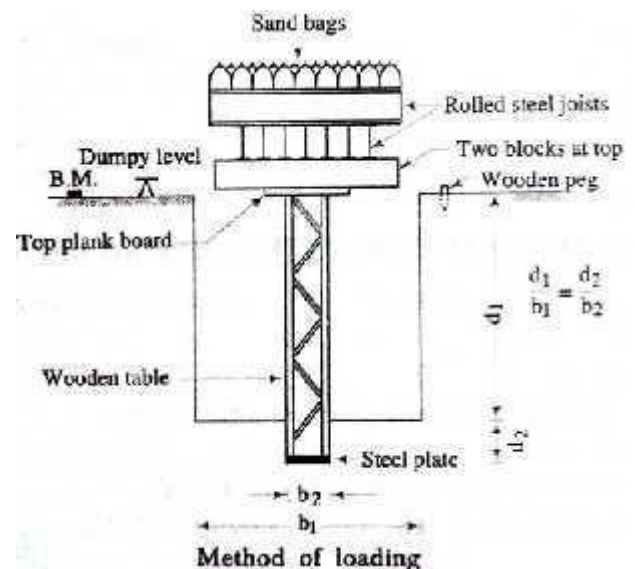



- iii. The steel plate placed and platform is prepared as shown in fig.
- iv. The amount of initial load is decided according to the type of soil to be tested. The weights of steel plates, wooden table and wooden beam should be carefully worked out.
- v. A dumpy level is planted to note the settlement of the steel plate with reference to a permanent bench mark.
- vi. The load is to be kept on the platform till the settlement of the ground ceases or stops.
- vii. Then the load is increased by a suitable amount, usually by 5KN and the procedure is continued. For this purpose the weighed sand bags are used.

Date and time of taking the reading	Load	Increase in settlement	Total settlement	Remarks
	5 kN	a	a	
		b	a + b	
		c	a + b + c	
	10 kN	a <sub>1</sub>	(a + b + c) + a <sub>1</sub>	Settlement
		b <sub>1</sub>	(a + b + c) + a <sub>1</sub> + b <sub>1</sub>	
		c <sub>1</sub>	(a + b + c) + a <sub>1</sub> + b <sub>1</sub> + c <sub>1</sub>	

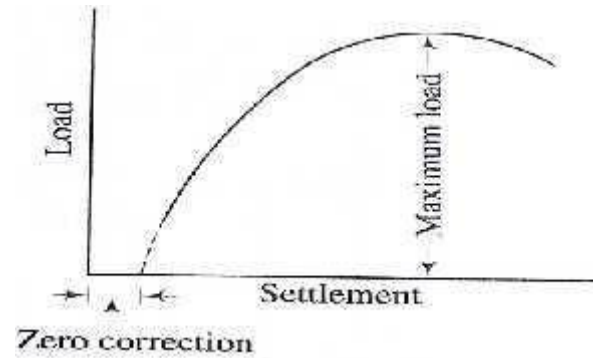

viii. A graph of load-settlement is plotted.

**Bearing capacity of Soil in  $\text{KN/m}^2$**  = Maximum Load / area of steel Plate

**Safe Bearing capacity of soil in  $\text{KN/m}^2$**  = Bearing Capacity of soil / FOS

2. **Plate load test:** This is the improved refined method and it is widely used for determining the bearing capacity of soil for important civil engineering structures.

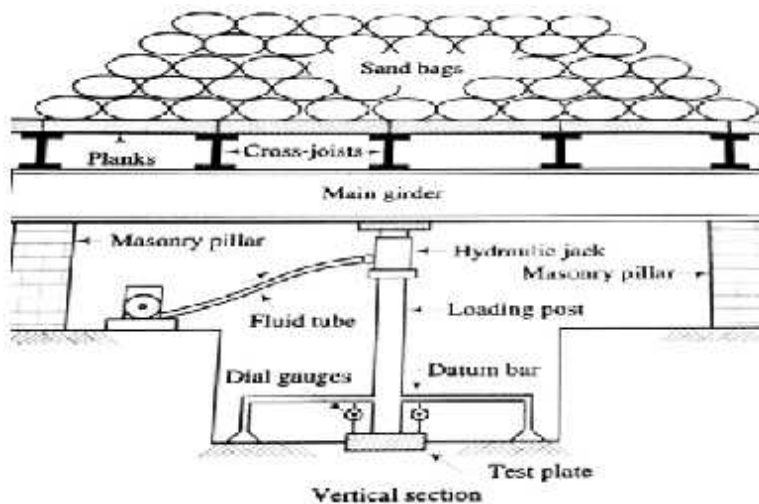

The procedure to carry out the plate load test is as follows:

1. The test pit and the square hole for the steel plate are made as in the previous method. The plate is firmly seated in the hole. If the ground is slightly uneven, a thin layer of sand is spread below the plate. The loading is done with the help of sand bags, stones or concrete blocks.
2. The load is applied in convenient increments say about  $1/5^{\text{th}}$  of the expected safe bearing capacity or  $1/10^{\text{th}}$  of the ultimate bearing capacity
3. The settlement of the plate is observed by two sensitive dial gauges which are fixed at diametrically opposite ends and supported independently on a suitable datum bar. The sensitivity of the dial gauges should be 0.02mm.
4. As the plate settles, the ram of the dial gauges moves down and settlement is recorded. The load is indicated on the load gauge of the hydraulic jack. The settlement should be observed for each increment of load after an interval of 1, 4, 10, 20, 40 and 60 min and thereafter at hourly intervals.
5. The recording of settlement is continued until the rate of settlement becomes less than 0.02mm per hour. The next load increment is then applied. The maximum load that is to be applied corresponds to 1.50 times the estimated ultimate load or 3 times the proposed allowable bearing pressure.
6. The load-settlement curve is plotted.

**3. Method of dropping a weight or penetration test:** In this method, a substance of known weight is dropped from a known height. The depth of impression made by the weight on the soil is noted. Then bearing capacity is determined as follows

$R$  = resistance of soil

$h$  = height

$d$  = depth of impression

$w$  = weight of the substance

Then Total energy

$$R * d = w * h$$

$$R = w * h / d$$

$A$  = cross section area of the substance

$R/A$  = resistance of the soil per unit area

Therefore Safe Bearing capacity of soil =  $R / (A * f)$

Where  $f$  = factor of safety

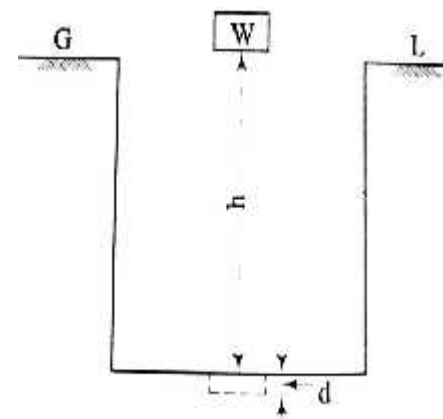

Method of dropping a weight

**4. Analytical methods:** The analytical methods involving the use of soil parameters like angle of internal friction and cohesion are now available to determine the ultimate bearing capacity of soil.

**5. Presumptive values of bearing capacities of soils:** The presumptive value of maximum safe bearing capacity of various soils is now available from codes or other sources which are adopted for designing the foundations for light loaded structures.

### **Increasing the bearing Capacity of soil**

Sometimes the required safe bearing capacity of the soil is not available at shallow depth or it is so low that the dimension of the footing works out to be very large and uneconomical. Under such circumstances, it becomes necessary to increase the bearing capacity of soil.

### **Methods for increasing the bearing capacity of soil**

- 1. Increase in depth of foundation:** For granular soils, bearing capacity increases with the depth of foundation due to confining weight of overlying material. This method is however not economical because the cost of construction increases with the depth and the load on the foundation also increases with increase in depth. This method is adopted only when more depth of foundation can be justified by the type and nature of structure to be supported over the soil.
- 2. Compacting Soil:** In this method the width of foundation is increased about 450mm or so and then a layer of 300mm to 450mm rubble is placed over the bottom of the foundation. This layer of rubble is well rammed and if this is buried completely then another layer of depth about 150 to 250mm is laid and it is well rammed. At the end of this process, if the bearing capacity of the soil is tested, it is found to have increased considerably. This value is used for designing the foundation.

The compaction of soil can also be achieved by various other means like

- **Flooding the soil:** The bearing capacity of very loose sand can be increased effectively by flooding the soil.
- **Ramming moist soil:** The soil is made wet and it is then compacted with the help of hand, mechanical rammers or vibratory rollers. The voids of the soil are reduced considerably and it results in the improvement of the bearing capacity of the soil.
- **Vibration:** If a layer of granular soils to a depth of 1m to 3m is compacted with the help of vibratory rollers, there is considerable increase in the safe bearing capacity of soil and the chances of settlements are minimized.
- **Vibroflotation:** This is a commercial method and it combines the effect of vibration with jetting. It is very useful especially when the foundation is required to support heavy loads spread over a greater area. The process is carried out as follows:
  - a. A heavy cylinder, known as vibroflot is inserted into the ground while the cylinder vibrates due to a rotary action
  - b. A large amount of water under pressure is supplied from the water jet provided on the tip of the vibroflot.
  - c. As the vibroflot sinks, the clean sand is added in the crater which is formed on the surface.

- d. The procedure is repeated to cover desired area of the foundation.
3. **Drainage of soil:** The presence of water decreases the bearing capacity of soil. Suitable drains should be provided in the foundation trench to drain off the excess water. If a spring is met with or if water finds its way through the cracks on the surface of the rock, the pipes are provided and thereby the uplift pressure is decreased. The pipes are then sealed at top.
  4. **Sheet Piles:** The movement of soil under the action of load can be prevented by confining the ground by the use of sheet pile. This will result in the increase of bearing power of soil.
  5. **Sand Piles:** The construction of sand piles proves to be very useful in case of sandy soils or soft soils.
  6. **Grouting:** The bore holes in sufficient numbers are driven in the ground. The cement grout is then forced under pressure through these bore holes. The cracks on the surface of rock are thus filled up, resulting in the increase of bearing power of soil.
  7. **Chemical treatment:** In this treatment, certain chemicals which can solidify and gain early strength are used in place of cement paste grout to solidify the soil. But as this process is costly, it is adopted only in case of important buildings.
  8. **Stone columns:** Stone columns are invariably used in weak soils having very poor bearing capacity. It is normally used in soft inorganic soils. Pieces of stones are well compacted in pre-bored holes to form stone column which acts as reinforcement, confines the soil and improves bearing capacity.
  9. **Use of geo-synthetics:** Geo-synthetics are used as reinforcing material which improves the ground condition. The bearing capacity of such soils is improved by 300% by using geo-synthetics. The various types of geo-synthetics are
    - (1) Geo-textiles
    - (2) Geo-grids
    - (3) Geo-cells
    - (4) Geo-drains etc.
- The above materials when reinforced in weak soils enhance its shearing resistance. Nowadays geo-grids are more employed for draining out water from a trench because of its porous nature.
10. **Compaction by deep blasting:** In this case a bore hole is dug for a depth of  $3/4^{\text{th}}$  or  $2/3^{\text{rd}}$  of total depth. Suitable explosive is placed at the bottom of hole and the charge is carried by cordex and connected to the electric detonator. When the explosive is detonated, it creates a cavity. The cavity expansion produces shock waves which densifies the soil. Normally 15 to 45gms of explosive are used for densification of soil.

**2.1.6 Types of Foundation**

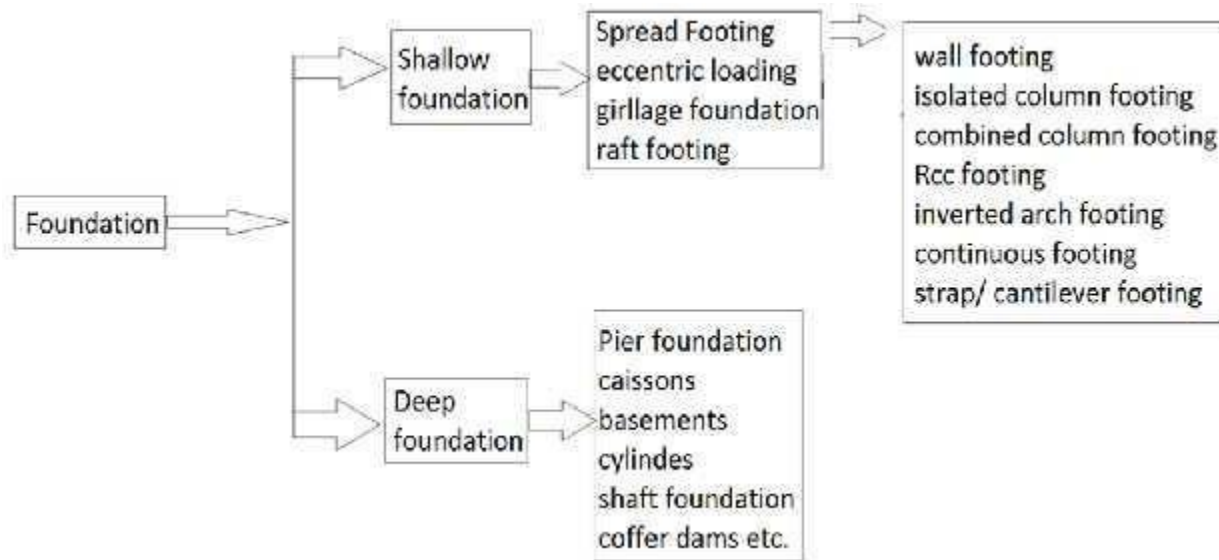

Foundations may be broadly classified into 2 types;

- a) Shallow Foundations
- b) Deep Foundations.

According to Terzaghi, A foundation is shallow if its depth is equal to or less than its width. Foundation is said to be deep if its depth is greater than its width.

**Shallow foundations**

Types of shallow foundations:

**a) Spread footing**

- ◆ It spread the super imposed load of wall or column over a large area
- ◆ It supports either a column or wall

It may be of the following types:

- i) Single footing for a column
- ii) Stepped footing for a column
- iii) Sloped footing for a column

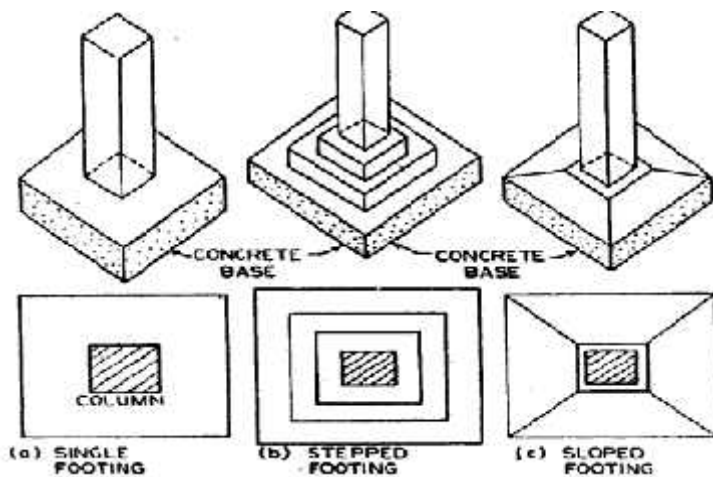

## Wall Footing

- If the wall directly rests on foundation concrete without any step, it is called simple footing.
- Stepped footing is used for a heavily loaded column which requires greater spread.
- Wall footing is a type of footing which is provided to support the wall.

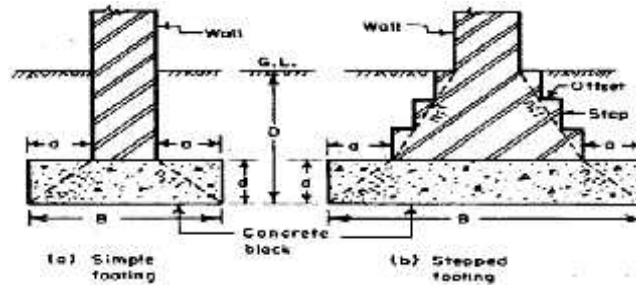

## Isolated Column footing

Isolated footings are most commonly used footings for Reinforced cement concrete column because it is simple and most economical. An isolated footing is used to support a single column. Isolated footings are independent footings which are provided for each column.

This type of footing is used when

- Columns are not closely spaced.
- Loads on footings are less.
- The Safe bearing capacity of the soil is generally high.

The Isolated footings essentially consist of a bottom slab. There are three basic types of bottom slabs are:

- Pad footing (with uniform thickness)
- Stepped footing (with non-uniform thickness)
- Sloped footing (trapezoidal section)

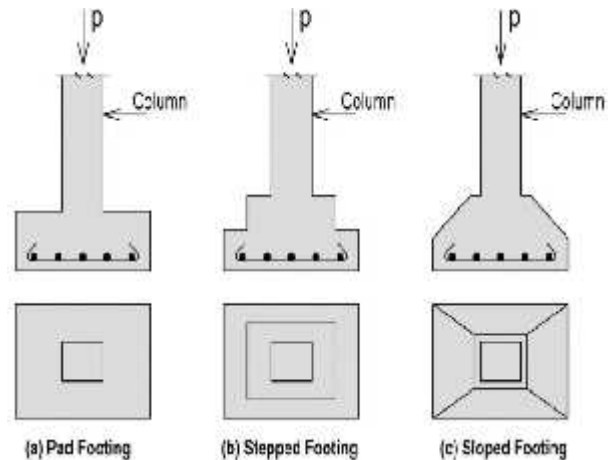

## Combined footings

A spread footing which supports 2 or more columns is termed as combined footing. It is classified as:

- Rectangular combined footings
- Trapezoidal combined footings
- Combined column wall footings

- It will be in rectangular shape if they carry equal loads
- The design of rigid rectangular combined footing should be done in such a way that center of gravity of column loads coincide with centroid of footing area.
- It will be trapezoidal if the columns carry unequal loads.

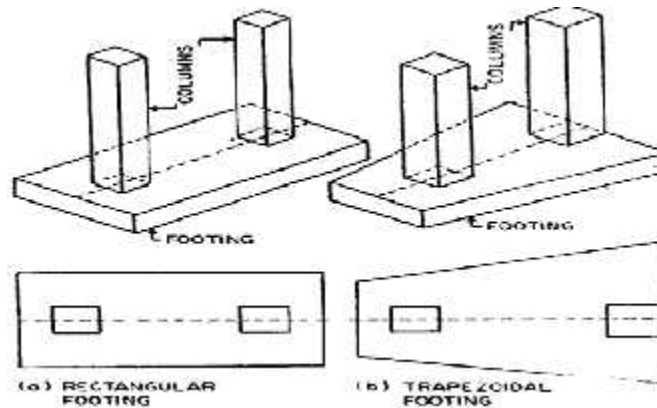

### Strap footings

- If the independent footings of two columns are connected by a beam, it is called strap footing
- It is required where the distance between the columns are great so that combined trapezoidal footings become quite narrow with high bending moments.
- Each column is provided with independent footings and a beam is used to connect the two footings
- The strap beam does not remain in contact with soil and thus does not transfer any pressure to the soil
- The strap is assumed to be stiff and transfer the column loads to the soil with equal and uniform pressure.

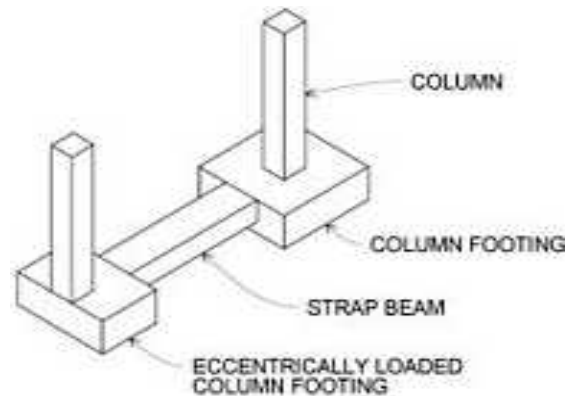

### Continuous Footings:

If a footing is common to more than two columns in a row, it is called continuous footing. This type of footing is necessary, if the columns in a row are closer or if SBC of soil is low.

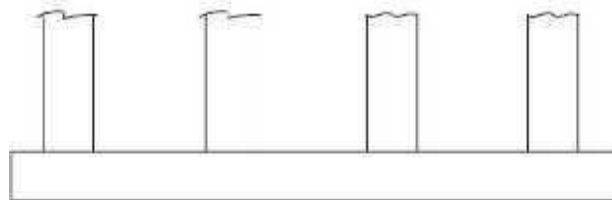

## RCC Footing

There are mainly two types of R.C.C. footings

1. One way reinforced footings.
2. Two way reinforced footings

1. **One Way Reinforced Footing:** These footings are for the walls. In these footings main reinforcements are in the transverse direction of wall. In longitudinal directions there will be only nominal reinforcement.

2. **Two Way Reinforced Footings:** For columns two way reinforced footings are provided.

## Inverted Arch Footing

Inverted Arch Footing is used to be provided for multi-storeyed buildings in olden times. However, the advantage of inverted arch construction is that in soft soils the depth of foundation is greatly reduced. This of foundation is not commonly used for buildings, but it is quite suitable for other structures like bridges, reservoirs, tanks, supports for drainage lines etc

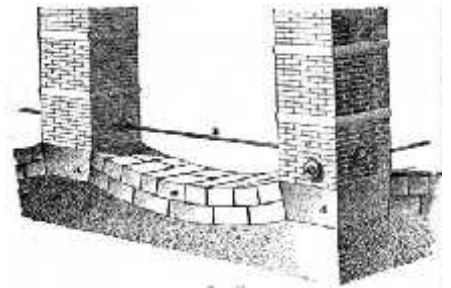

## Grillage Foundation

- It is special type of isolated footing
- It is used where the bearing capacity of the soil is poor
- The depth of foundation is limited to 1 to 1.5m
- The load is spread to very large area by means of 2 or more tiers of rolled steel joists and the tiers are embedded in cement concrete to keep the joists in position and to prevent corrosion.
- This type of foundation is also constructed in timber beams and planks.

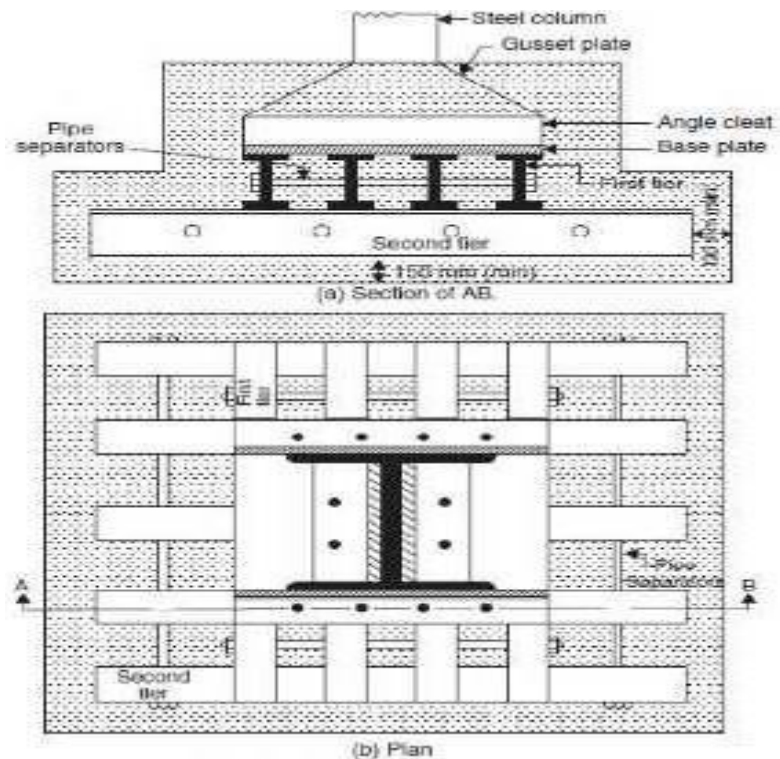



### Raft or Mat foundation

- A raft or mat is a combined footing that converts the entire area beneath a structure and supports all the wall and columns
- It is more economical when the soil pressure is low and it covers one half the areas
- They are also used where it is difficult to control differential settlements in soil.
- Raft foundation is also used to reduce settlement by making the weight of structure equal to weight of soil excavated

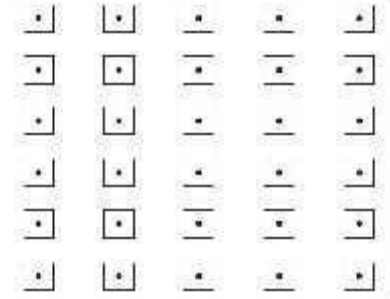

It may be divided into 3 types

- Solid slab system
- Beam slab system
- Cellular system

All the 3 types are consisting of large area of slab covering the whole part of structure. The thickness of slab and size of beams is governed by spacing and loading of the column.

### Eccentric Loaded Footing

The footings are so designed and proportioned that the C.G. of the superimposed load coincides with the C.G. of the base area, so that the footing is subjected to concentric loading, resulting in uniform bearing pressure. However, in some cases, it may not be possible to do so. For example, if the wall (or column) under construction is near some other property, it will not be possible to spread the footing to both the sides of the wall or column.

$W_1$  = Super-imposed load, including the weight of wall, per unit length  
 $W_2$  = Weight of foundation.  
 $W$  = Resultant load on the base.

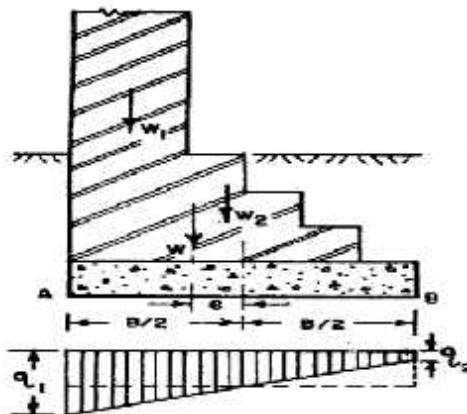

## Types of Deep Foundation

### Pile foundation:

- It is deep foundation where the loads are taken to a low level by means of vertical members which may be of timber, concrete or steel
- It is adopted when loading is uneven and no firm bearing strata exists at reasonable depths.
- When a firm bearing strata does not exist but at such depths, strip or spread footing is uneconomical, it is used.
- When pumping of subsoil water would be too costly it is used.

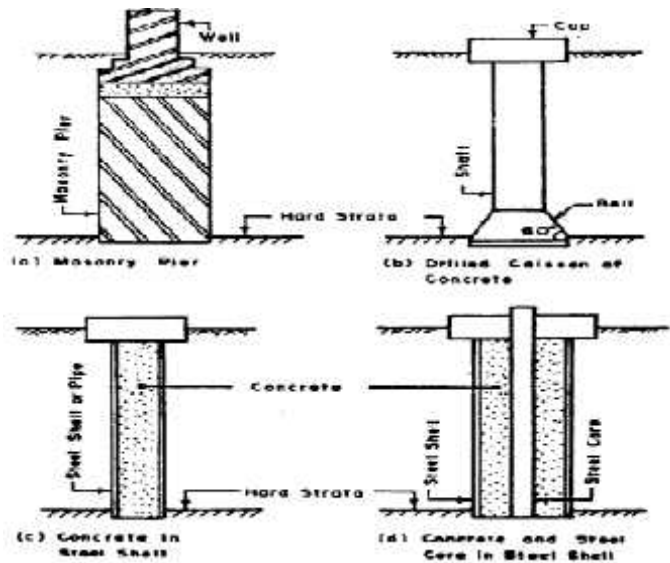

Piles used for buildings may be following types:

- End Bearing piles
- Friction piles
- Combined end bearing and friction piles
- Compaction piles

End bearing piles are used to transfer load through water or soft soil to a suitable bearing stratum. Such piles are used to carry heavy loads safely to hard strata. Multi storied buildings are found on end bearing piles to minimize settlements.

Friction piles are used to transfer loads by friction-load carrying material by means of skin friction. Such piles are used in granular soil for hard stratum.

Combined end bearing and friction piles transfer the super imposed load both through side friction as well as end bearing. It is mostly used in granular soil.

Compaction piles are used to compact loose granular soils thus increasing their bearing capacity. The compaction piles themselves do not carry load by it but it carry by weaker material like timber, bamboo sticks and sands.

### Well foundation or caissons

- Well foundations are box like structure - circular or rectangular which is sunk from the surface.
- They are much large in diameter compared to other deep foundations.
- They are hollow from inside and filled with sand and plugged at the bottom.

- The load is transferred through perimeter wall called steining.

It is used for major works like:

- Bridge piers and abutments in rivers, lakes etc
- Large water front structures such as pump houses

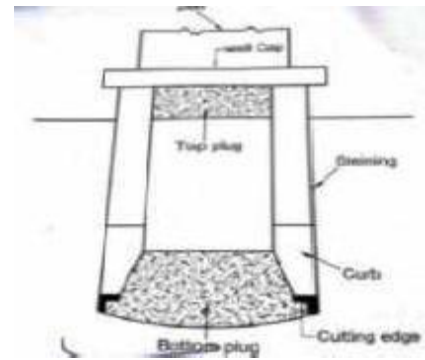

## 2.1.7 MASONRY

notes4free.in

### Introduction

- The term masonry is used to indicate the art of building the structures in either stones or bricks.
- It may be defined as the construction of building units bonded together with mortar.
- The masonry is used for the construction of foundations, walls, columns and othersimilar components of a structure.

Depending upon the type of material used, masonry can be broadly divided in the following categories:

- Stone masonry
- Brick masonry
- Reinforced masonry
- Hollow concrete block masonry
- Load bearing wall tile masonry

### Terminology

1. **Arrises:** The edge formed by the intersection of plane surfaces of brick is called the arrises.
2. **Bed:** The lower surface of a brick or stone in each course.
3. **Course:** a Course is a horizontal layer of masonry

4. **Bed joint:** the horizontal layer of mortar upon which the bricks or stones are laid is known as a bed joint.
5. **Stretcher:** a stretcher is the longer face of the brick (23cm X 11.4cm) as seen in the elevation of the wall. A course of bricks in which all the bricks are laid as stretchers on facing is known as a stretcher course.
6. **Header:** it is the shorter face of the brick (11.4cm X 7.6cm) as seen in the elevation of the wall. A course of bricks in which all the bricks are laid as headers on facing is known as header course.
7. **Quoins:** the exterior angle or corner of a wall is known as quoin. The stones or bricks forming the quoins are known as stone quoins or quoin bricks.
8. **Lap:** the horizontal distance between the vertical joints in successive courses is termed lap.
9. **Perpend:** It is an imaginary vertical line which includes the vertical joint separating two adjoining bricks.

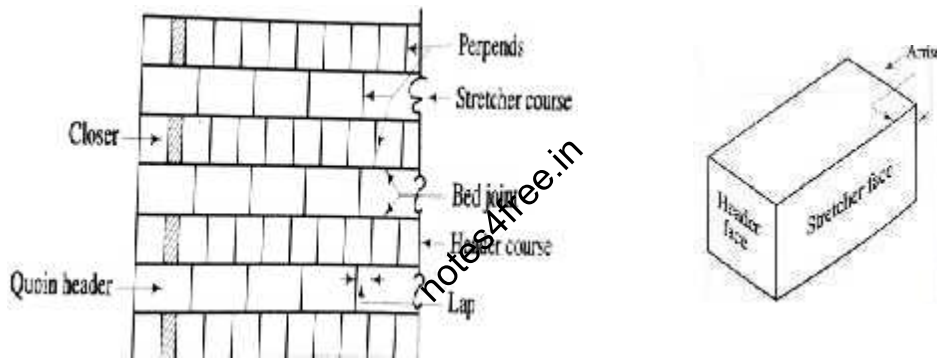

10. **Closer:** A piece of brick which is used to close up the bond at the end of brick courses is known as a closer. Following are the types of closers:

- i. Queen closer
- ii. King closer
- iii. Beveled closer
- iv. Mitred closer

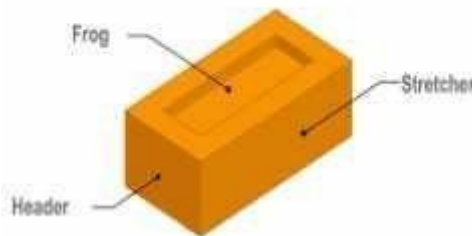
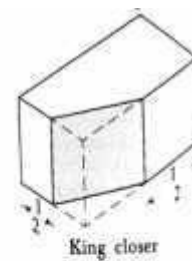
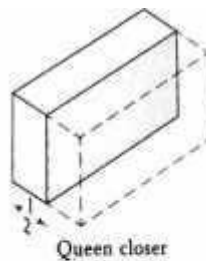
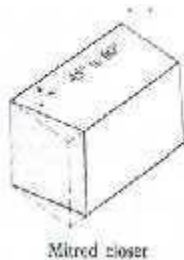

11. **Bat:** It is the portion of the brick cut across the width. Thus, a bat is smaller in length than the full brick.

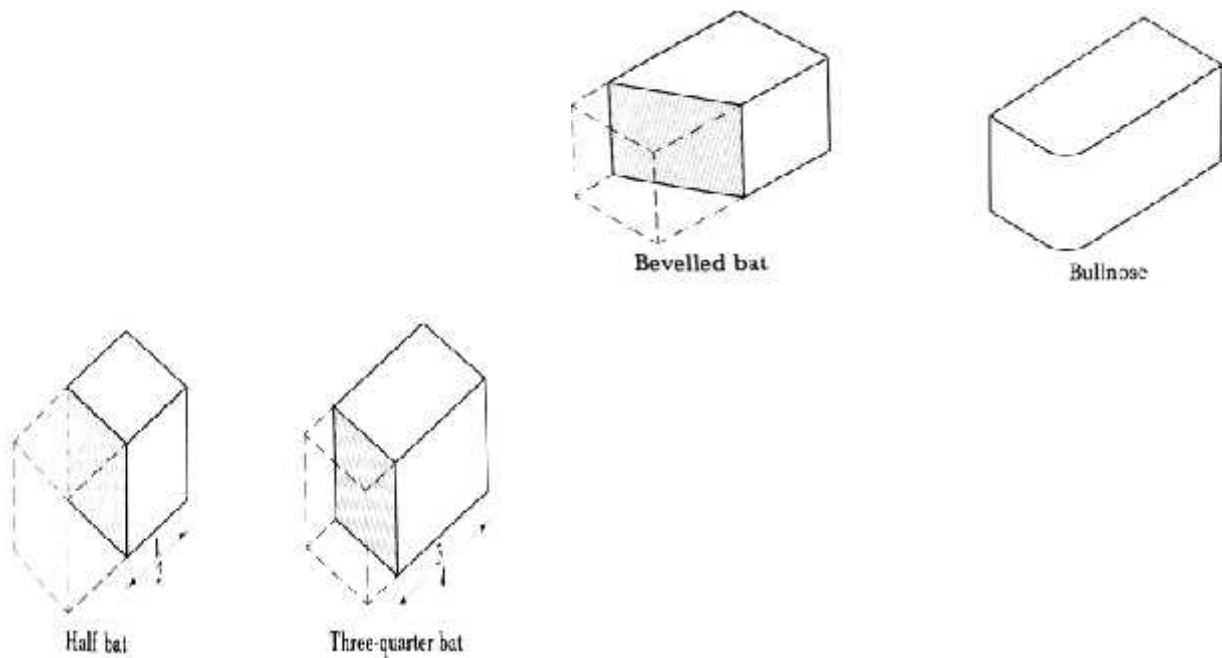

## Brick Masonry

Construction of brick units bonded together with mortar is termed as brick masonry. Two essential components of brick masonry are

1. Bricks
2. Mortar

## Bricks

Bricks are the products of the clay. It is defined as a small, solid building unit in the shape of a rectangular block composed of inorganic, non metallic substances of mineral origin and hardened by heat.

## Types of Bricks

Bricks used in masonry are of two

### 1. Traditional Bricks

- These are those which are not standardized in size.
- The dimensions of traditional bricks vary from 20 to 25cm in length, 10 to 13cm in width and 5-7.6cm in thickness (height).
- The commonly adopted size of traditional brick is 23cm X 11.4cm X 7.6cm.
- The average weight of a brick will be about 3 to 3.5kg.

### 2. Modular brick

- If bricks are large, it is difficult to burn them properly and they become too heavy to be placed with a single hand.
- On the other hand if bricks are small, more quantity of mortar is required.
- Hence BIS has recommended the bricks of uniform size. Such bricks are known as modular bricks.
- Nominal size of these bricks is 20cm x 10cm x 10cm.

### **Mortar**

- Mortar acts as a cementing material and unites the individual brick units together to act as a homogeneous mass.
- Mortar is a homogeneous mixture produced by uniform mixing of a binder with sand and water to make a paste of required consistency.

Following are the types of mortar used in masonry

1. Mud mortar
2. Cement mortar
3. Lime mortar
4. Gauged mortar

### **Bonds in Brick work**

- A bond is an arrangement of layers of stones or bricks by which no continuous vertical joints are formed.
- Bond is the interlacement of bricks, formed when they lay those immediately below or above them.
- Bonds of various types are distinguished by their elevation or face appearance
- It is essential to eliminate continuous vertical joints in the face of the wall.
- The bond distributes the load coming on the structure evenly and prevents the formation of a vertical crack
- A wall having continuous vertical joint does not act as a homogeneous mass to distribute the super imposed loads.

### **Types of Bonds**

Following are the types of bonds provided in brick work.

1. Stretcher bond
2. Header bond
3. English bond
4. Flemish bond
5. Facing bond

6. Dutch bond
7. Raking bond
8. Zigzag bond
9. English cross bond
10. Garden wall bond
11. Brick on edge bond

### Stretcher bond

- In this type of bond, all the bricks are arranged in the stretcher course
- The stretcher course will be useful for one-brick partition walls as there are no headers in such walls.
- As this bond does not develop proper internal bond, it should not be used for walls having thickness greater than that of one-brick wall.

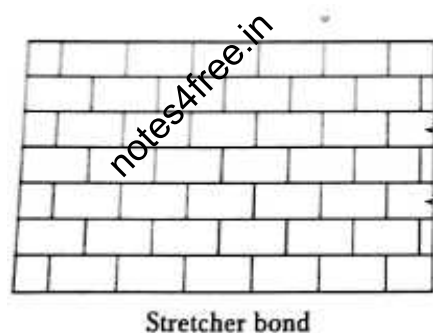

### Header Bond

- In this type of bond, all the bricks are arranged in header course.
- The overlap is usually kept equal to half the width of brick and it is achieved by using three-quarter brickbats in each courses.
- The bond does not have strength to transmit pressure in the direction of the length of the wall. Hence it is not suitable for load bearing walls.
- However this bond is used for curved surfaces in brickwork because stretchers, if used for curved surfaces, would project beyond the face of the wall

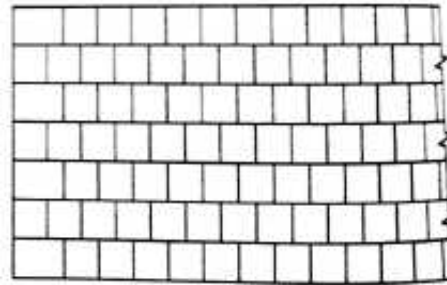

Header bond

### English bond

This is the most commonly used bond. It is considered to be the strongest bond. Following are the features of English bond

- It consists of alternate courses of headers and stretchers
- In this bond, vertical joints of the header courses come over each other, similarly the vertical joints of the stretcher courses also come over each other.
- There is no continuous vertical joint
- Every alternate header comes centrally over the joint between two stretchers in course below.
- In the stretcher course, the stretchers have a minimum lap of  $\frac{1}{4}$ th their length over headers.
- The queen closers are not required in stretcher courses.

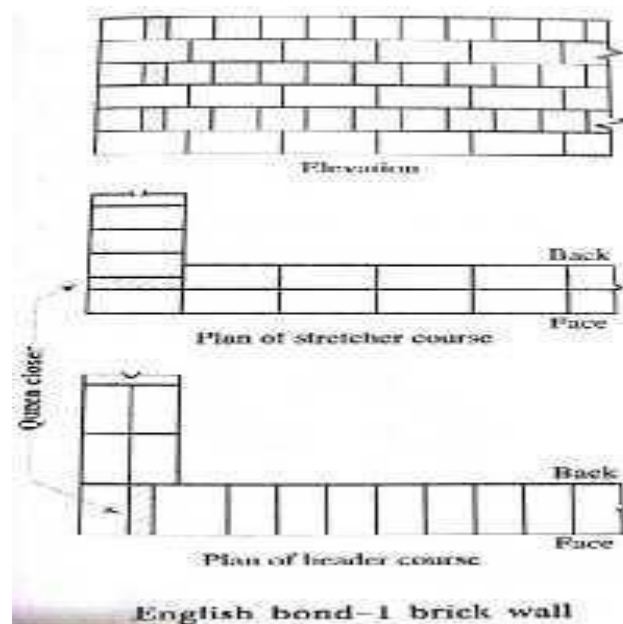

### Flemish bond



- In this type of bond, each course is comprised of alternate headers and stretchers.
- Every alternate course starts with a header at the corner (quoin header).
- Quoin closers are placed next to the quoin header in alternate courses to develop the face lap.
- Every header is centrally supported over the stretcher below it.

Flemish bonds are two types:

1. Single Flemish bond
2. Double Flemish bond

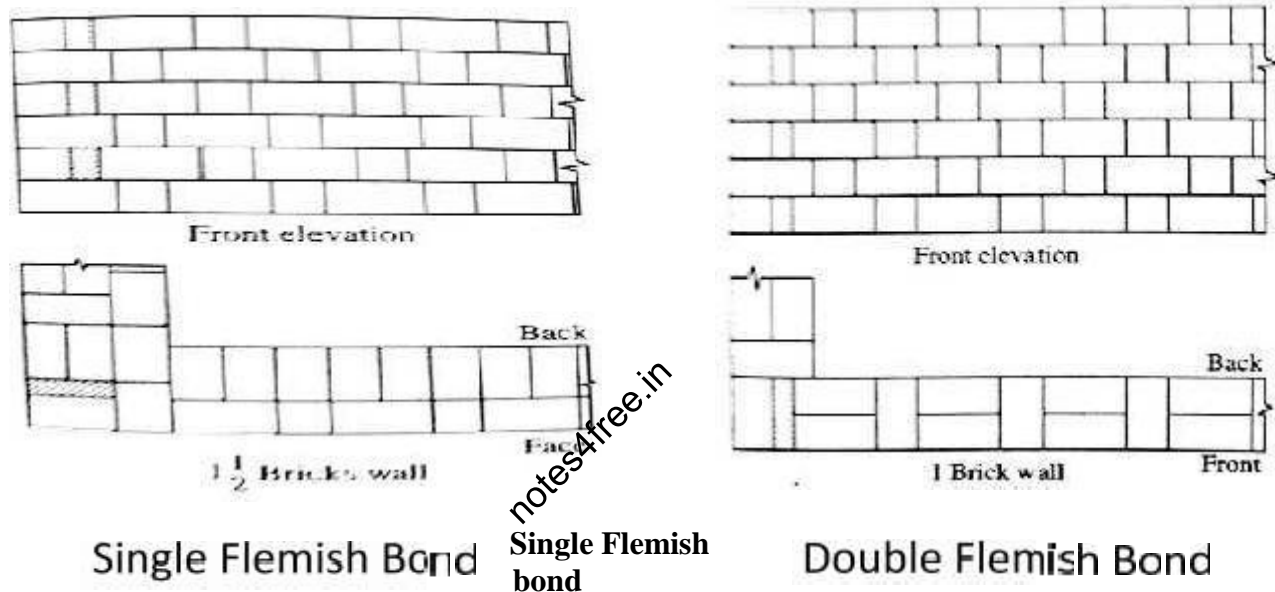

1. This bond is a combination of English and Flemish bond.
2. This bond uses the strength of the English bond and appearance of Flemish bond
3. In this work the facing of the wall consists of Flemish bond and the backing consists of English bond in each course.
4. It is used for those walls having thickness at least equal to 1 1/2 brick.

### Double Flemish bond

1. Alternate headers and stretcher are laid in each course.
2. The facing and backing of the wall, in each course have the same appearance.
3. In walls having thickness equal to odd multiple of half bricks, half bats and 3 1/4 bats are amply used
4. For walls having thickness equal to even multiple of half bricks, no bats are required. A header or stretcher will come out as header or stretcher on the same course in front as well as back faces.

### Comparison of English bond and Flemish bond

1. English bond is stronger than Flemish bond for walls thicker than 1 1/2 brick
2. Flemish bond gives more pleasing appearance than the English bond.

3. Broken bricks can be used in the form of bats in Flemish bond. However more mortar is required.
4. Construction with Flemish bond requires greater skill in comparison to English bond.

### Requirements of Brick masonry

- Good brick masonry should utilize the bricks which should be sound, hard, tough, durable, and uniform in color, size and shape.
- The bricks should be compact, homogeneous, free from cracks, lumps or voids.
- In the brickwork, bricks should be laid on their beds with frogs pointing upwards.
- The bricks should be laid horizontally and should have truly vertical joints.
- As far as possible, avoid the use of brick bats.
- After the construction of brick masonry, it has to be cured for 2-3 weeks in case of lime mortar & 1-2 weeks for cement mortar.
- In order to carry out brickwork at higher level, scaffolding is used.

### Stone Masonry

Construction of stone units bonded together with mortar is termed as stone masonry. Two essential components of brick masonry are

1. Stones
2. Mortar

notes4free.in

### Commonly used stones for masonry

Some of the stones found in India and their uses as follows:

1. **Granite (Igneous rock):** It is used for heavy engineering works for bridge piers, columns, retaining wall, random rubble, foundation, dressed stone work and for coarse aggregates in concrete.
2. They can also be used in slabs and polished to be used as floor slabs and stone facing slabs.
3. **Basalted Trap (Igneous rock):** They have the same use as granite. Deccan trap is a well known stone of this group in south India.
4. **Gneiss (Metamorphic rock):** It is used in the same way as granite. It can be identified by its elongated plates minerals often mixed with mica.
5. **Quartzite (Metamorphic rock):** It is also used in the same way as granite but it is not used for ornamental work as it is brittle.
6. **Slate (Metamorphic rock):** It is used for damp proofing, flooring and flooring.
7. **Marble (Metamorphic rock):** It is used for ornamental, flooring and stone facing slabs.

8. **Lime stone (Sedimentary):** It is used for the walls as coarse aggregate for concrete and also as a base material for cement.
9. **Sand stones (Sedimentary):** They are used for ornamental work and paving.
10. **Laterite (Decomposed from igneous rocks):** It can occur in hard and soft varieties. The soft variety is used for paving the pathways.

### Classification of Stone Masonry

Depending upon the arrangement of stones in the construction, degree of refinement used in shaping the stone and finishing adopted, the stone masonry can be classified as follows

#### Rubble Masonry

1. Coursed Rubble
2. Uncoursed Rubble
3. Random Rubble
4. Dry Rubble
5. Polygonal Rubble
6. Flint Rubble

#### Ashlar Masonry

1. Ashlar fine
2. Ashlar rough tooled
3. Ashlar rock/quarry faced
4. Ashlar chamfered
5. Ashlar block in course
6. Ashlar facing

notes4free.in

### Requirements of stone masonry

1. The stones to be used for masonry should be hard, tough and durable.
2. The pressure acting on the stones should be vertical
3. For effective transfer of load, stones should be laid flat.
4. The stones should be dressed as per requirements.
5. The mortar to be used should be good quality.
6. The construction work should be raised uniformly
7. As far as possible, broken stones should not be used.

### Rubble Masonry

- In this type of construction, the stones of irregular size are used.
- The stones are obtained from quarry are taken in use in the same form or they are broken and shaped in suitable sizes by means of hammer as the work proceeds.

➤ Since stones of irregular size are used, the masonry will have wide joints.

The strength of rubble masonry mainly depends on three factors

- The quality of mortar
- The used of long through stones at frequent intervals
- The proper filling of the mortar between the spaces of stones.

### 1. Coursed rubble masonry

- In this heights of stones vary from 50mm to 200mm.
- The masonry work is carried out in courses such that the stones in a particular course are of equal heights.
- This type of masonry is used for the construction for public buildings, residential buildings etc. the course rubble masonry is further divide into 3 categories:

#### a. Coursed rubble masonry I sort:

- In this type, the stones of the same height are used and the courses are also of same height.
- The faces of stones are dresses by means of hammer
- The thickness of joint should not exceed 10mm

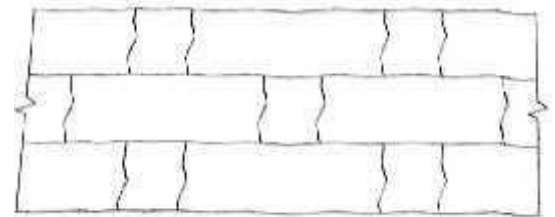

Coursed rubble masonry I sort

#### b. Coursed rubble masonry II sort:

- The stones to be used are of different heights.
- The courses need not to be of equal heights.
- Only 2 stones are used to make height of one course.
- The thickness of joint should not exceed 12mm

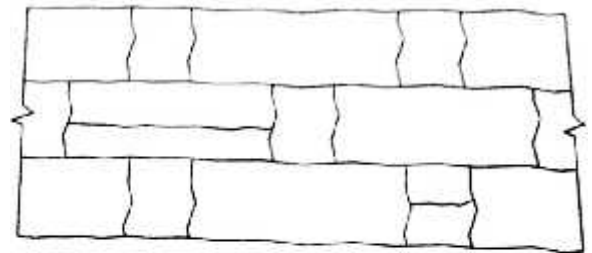

Coursed rubble masonry II sort

#### c. Coursed rubble masonry III sort:

- The stones are of different heights.
- The courses need not to be of equal heights.
- Only 3 stones are to be used to make up the height of one course.
- The thickness of joint should not exceed 16mm

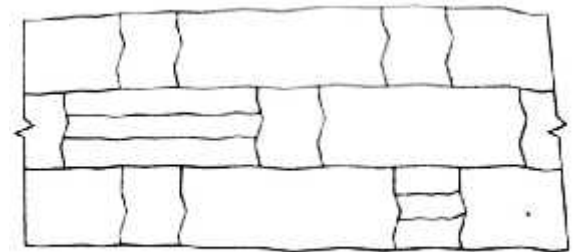

Coursed rubble masonry III sort

## 2. Uncoursed rubble masonry

- This is the poorest form of stone masonry.
- Stones are not dressed
- The stones to be used for the work are directly obtained from the quarry.
- The larger stones are laid first and the spaces between them are then filled up by means of spalls or snecks.
- Courses are not maintained regularly. But for every 300 to 500mm a level will be maintained.
- The thickness of joints should not exceed 13 mm
- Since it is cheaper, it is used for the construction of compound walls, gowdowns, garages, labour quarters etc

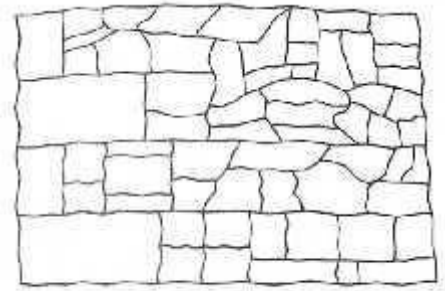

Uncoursed rubble masonry

## 3. Random rubble masonry

- This form is slightly superior to uncoursed rubble masonry
- In this type of masonry, the stones of irregular sizes and shapes are used.
- More skill is required to make this masonry structurally stable
- If the face stones are chisel-dressed and the thickness of mortar joints does not exceed 6mm, it is random rubble masonry I sort.
- If the face stones are hammer dressed and the thickness of mortar joints are hammer dresses and the thickness o mortar joints does not exceed 12mm, it is random rubble masonry II sort.
- This type of masonry used for the construction of residential buildings, compound walls, gowdowns etc.



Random rubble masonry

## 4. Dry Rubble Masonry

- Similar to that of coursed rubble masonry of III sort.
- But no mortar joint are used.
- Cheap
- Adopted for compound walls, pitching on bridge approachment.

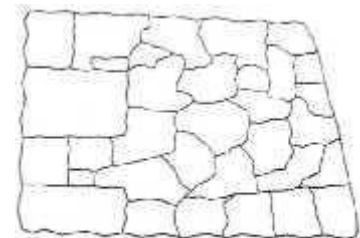

Polygonal rubble masonry

## 5. Polygonal Rubble Masonry

- Stones selected for the work is of irregular polygon shape
- Skilled labours are required in order to get better appearance

## 6. Flint rubble Masonry

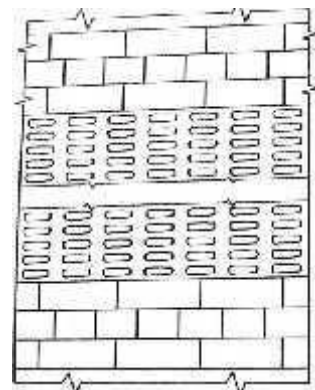

- Made of stones with irregular shape of lumps of silica on stone surface.

## Ashlar Masonry

- The work built from carefully dressed stones with accurate bedding and jointing is termed as ashlar masonry.
- In this type of construction, the square or rectangular blocks of stones are used.
- The courses are not necessary of the same height.
- The height of stones varies from 250mm to 300mm.
- The length of stones should not exceed 3 times the height and the depth into the wall should be at least equal to half the height.

### 1. Ashlar fine masonry

- All the stones are fine tooled on all beds and sides joints.
- The height of the course is never less than 30cm
- All courses are kept of same height.
- The height of stones used is never less than their breadth and their length not less than twice their height.
- The face stones are generally laid as header and stretcher alternately
- The thickness of the mortar joints should not exceed 3mm.
- It gives perfectly smooth appearance but it is costly in construction.

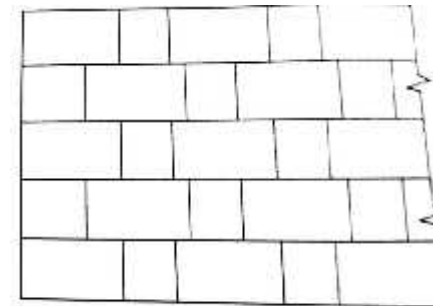

Ashlar fine masonry

### 2. Ashlar Rough Tooled

- The exposed faces of stone generally have a fine dressed chisel drafting all round the edges. But the face is made rough by means of tools.
- The thickness of mortar joints does not exceed 6mm.
- A strip about 25mm wide and made by means of a chisel is provided around the perimeter of every stone.

### 3. Ashlar rock or quarry faced masonry

- It is similar to ashlar rough tooled except that the exposed faces of face stones between the chisel drafting are left rough.
- Only the projections on the face, known as the bushings, exceeding 80mm are removed by a hammer. It gives massive appearance.

### 4. Ashlar chamfered masonry

- Here the strip is provided as above. But is chamfered at an angle of 45°.
- It is similar to Ashlar or quarry faced masonry. A neat appearance of the grooved joints is obtained.

### 5. Ashlar block in course masonry

- It occupies an intermediate position between rubble masonry and the ashlar masonry.
- The faces of the stones are generally hammer dressed and the thickness of mortar joints does not exceed 6mm.
- The depth of courses varies from 200mm to 300mm.
- It is used for heavy engineering works such as retaining walls etc.

### 6. Ashlar facing

- It is provided with brick or concrete block masonry to give better appearance.
- The sides and beds of each block are properly dressed so as to make them true to shape.
- The exposed faces of the stones are rough tooled and chamfered. The backing of wall may be made in brick masonry.

### Joints in Masonry

In order to secure the stones firmly with each other, the following joints are provided

1. Butt or square joint
2. Rebated or lapped joint
3. Tongued or grooved joint
4. Tabled joint
5. Saddle joint
6. Rusticated joint
7. Plugged joint
8. Dowelled joint
9. Cramped joint

notes4free.in

1. **Butt or square joint:** In this type square surface of one stone is placed against that of another.

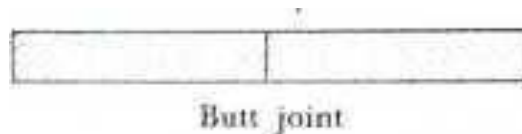

2. **Rebated or lapped joint:** in this type the rebates are provided which prevent the movements of stones. The length of the rebate depends on the nature of the work. But it should not be less than 70mm. this joint is used for arch work or on gables.

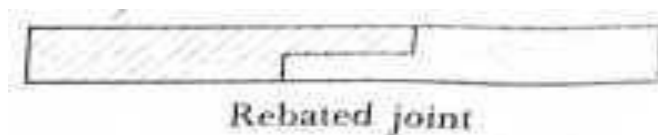

3. **Tongued joint:** In this type a projection is kept on the stone and a corresponding sinking is provided in the other stone over the other. This joint is also known as a joggle joint.

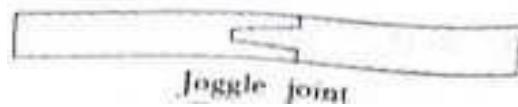

4. **Tabled joint:** In this type, a joggle is formed in the bed of the stone to prevent lateral movement. The depth of projection is about one-third the breadth of the stone. This type of joint is used in case of structure such as sea-walls where the lateral pressure is heavy.

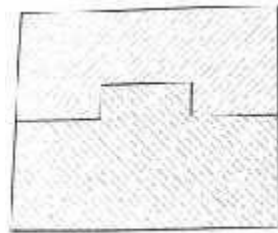

5. **Saddled or water joint:** In this type, the stone is rounded off. This type of joint is provided to protect the joints of the cornices and such other weathered surfaces.

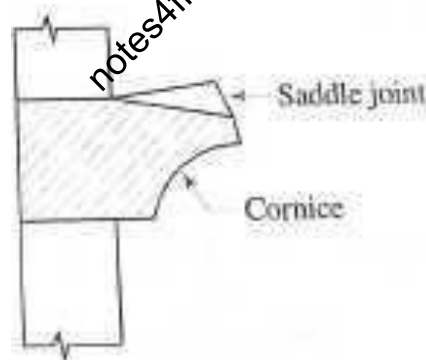

6. **Rusticated joint:** In this type, the cementing is made on the lower joint.

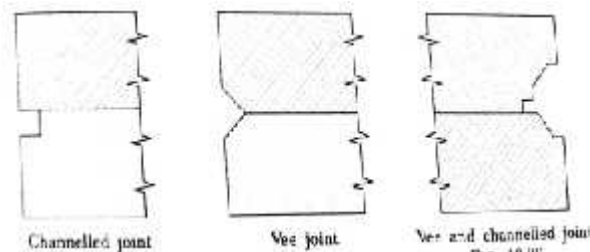

7. **Plugged joint:** In this type, the dove-tailed shaped mortices are provided in the sides of adjacent stones, when stones are placed in position.



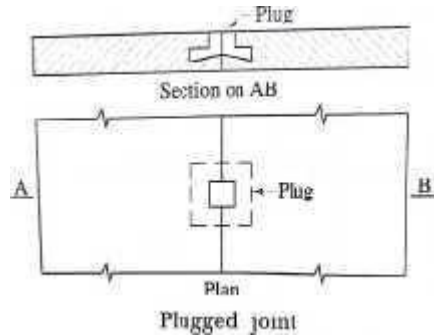

8. **Dowelled joint:** In this type, a hole is cut into each stone and a loose dowel, which is a small piece of hard stone, is inserted and removed with the cement. The dowels are generally 25mm thick and 100mm to 150mm long.

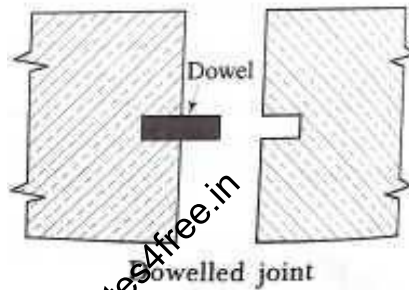

9. **Cramped joint:** In this type, cramps are used instead of dowels. The cramps are pieces of non-corrosive metals such as geometrical etc and their ends are turned down to a depth of about 40mm to 50mm. The length, width and thickness of the cramps vary from 200mm to 300mm, 25 to 50mm and 5 to 10mm respectively.

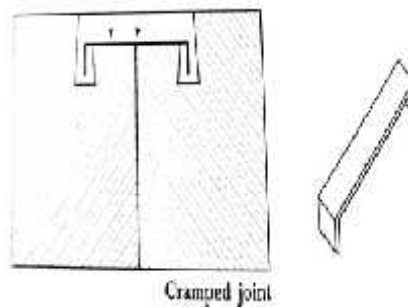

**Wall** is one of the most essential components of a building. The primary function of a wall is to enclose or divide space of the building to make it more functional and useful.

#### Functions of wall

- To provide protection from weather, animal
- To divide the areas

- Act as sound barriers
- As fire walls to attenuate the spread of fire from one building unit to another
- Separate the interior spaces
- To improve the building appearance
- To provide privacy

### Materials for Walls

Timber, brick, concrete block, reinforced concrete can be used for wall construction.

#### 2.1.8 Types of Walls

1. **Load bearing walls** are those which are designed to carry super-imposed loads, in addition to their own weight.
2. **Non load bearing walls** carry their own-load only. They generally serve as divide walls or partition walls.

#### Types of Load Bearing Wall

- Pre Cast Concrete Wall
- Retaining Wall
- Masonry Wall
- Pre Panelized Load Bearing Metal Stud Walls
- Engineering Brick Wall (115mm, 225mm)
- Stone Wall

#### Types of non load bearing wall

- Hollow Concrete Block
- Façade Bricks
- Hollow Bricks
- Brick Wall

A partition wall is a thin internal wall which is constructed to divide the space within the building into rooms or areas.

A partition wall should fulfill the following requirements:

1. The partition wall should be strong enough to carry its own load.
2. The partition wall should be strong enough to resist impact to which the of the building is likely to subject them.
3. The partition wall should have the capacity to support suitable decorative surface.

4. A partition wall should be stable and strong enough to support some wall.
5. A partition wall should be light.
6. A partition wall should be fire resistant.

**Types of partition walls:**

1. Brick
2. Clay block
3. Concrete
4. Glass
5. Asbestos sheet or GI sheet partitions
6. Timber partitions

Cavity walls are constructed with two separate walls for single wall purpose with some space or cavity between them.

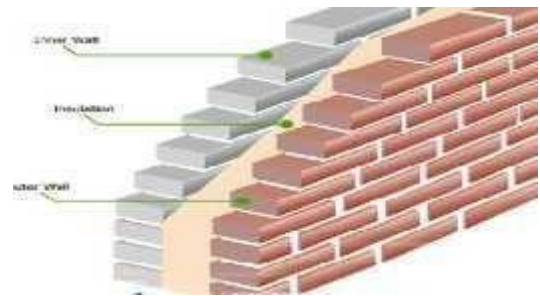
**Advantages of Cavity wall**

- Cavity walls give better thermal insulation than solid walls. It is because of the space provided between two leaves of cavity walls is full of air and reduces heat transmission into the building from outside.
- Economically they are cheaper than solid walls.
- Moisture content in outer atmosphere is does not allowed to enter because of hollow space between leaves. So, they also prevent dampness.
- They also act as good sound insulators.
- They also reduce the weights on foundation because of their lesser thickness.
- Outer Efflorescence is also prevented.

**2.2.9 Questions**

1. Briefly explain the terms used in masonry?
2. Explain the types of brick masonry?
3. Explain the types of stone masonry?

**2.2.10 Outcomes**

- Able to study the brick masonry work
- Able to distinguish brick and stone masonry work
- Will be knowing the types of brick and stone masonry

**2.2.11 Future Study**

[https://www.vssut.ac.in/lecture\\_notes/lecture1424085991.pdf1](https://www.vssut.ac.in/lecture_notes/lecture1424085991.pdf1)

notes4free.in

---

**MODULE 3 – LINTELS, BALCONY AND ARCHES****Structure**

- 3.1.1 Introduction to Lintels
- 3.1.2 Objectives
- 3.1.3 Classification
- 3.1.4 Method of construction
- 3.1.5 Questions
- 3.1.6 Outcome
- 3.1.7 Future study
- 3.2.1 Introduction to Chejja
- 3.2.2 Objective
- 3.2.3 Function
- 3.2.4 Method of construction
- 3.2.5 Types of Chejja
- 3.2.6 Questions
- 3.2.7 Outcome
- 3.2.8 Future study
- 3.3.1 Introduction to Canopy or Portico & Balcony
- 3.3.2 Objectives
- 3.3.3 Functions
- 3.3.4 Method of construction
- 3.3.5 Outcome
- 3.3.6 Questions
- 3.3.7 Future Study
- 3.4.1 Introduction to Masonry Arches
- 3.4.2 Objectives
- 3.4.3 Technical terms
- 3.4.4 Types of arches
- 3.4.5 Stability of an arch
- 3.4.6 Questions
- 3.4.7 Outcome
- 3.4.8 Future study

notes4free.in

## Lintels

### 3.1.1 Introduction

A lintel is a horizontal member which is placed across an opening to support the position of the structure above it. A lintel is thus a sort of beam in which width will be equal to the width of the wall, and the ends of which are built into the wall. In general, it should be seen that the bearing of the Lintel i.e., the distance up to which it is inserted in the supporting wall, should be the minimum on the following three considerations:

1. 100mm or
2. Height of lintel or
3.  $1/10^{\text{th}}$  or  $1/12^{\text{th}}$  of the span of lintel

### 3.1.2 Objectives

- To study the terms used in lintels
- To study the types of lintels
- To gain the knowledge on uses of lintels

### 3.1.3 Classification of Lintels

Lintels are classified into the following types according to the materials of construction:

1. Timber lintels
2. Stone lintels
3. Brick lintels
4. Steel lintels
5. Reinforced concrete lintels

#### 1. Wood or Timber lintels:

- These lintels consist of pieces of timber which are placed across the opening.
- These are used in hilly areas or in places where timber is easily available.
- These are structurally weak and vulnerable to fire.
- They are also liable to decay more comparative to other types.
- A bearing of about 15cm to 20cm should be provided and a minimum thickness of about 80mm should be provided in case of wooden lintel.

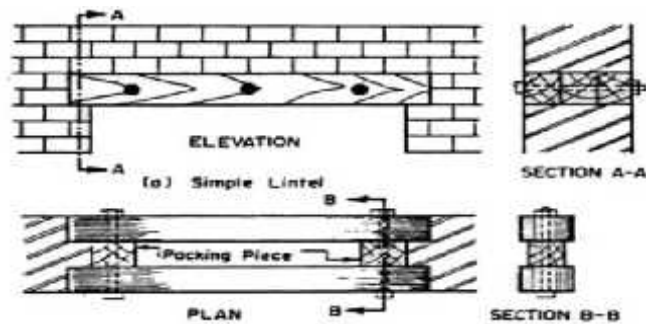

## 2. Stone Lintels

The thickness of stone lintel is kept equal to 10cm per meter of span with a minimum of 15cm.

They are not generally used because

- The stone possesses low tensile resistance
- It cracks if subjected to vibratory loads
- It is difficult to obtain a good stone of required depth and it proves to be costly at places where the stone is not available.

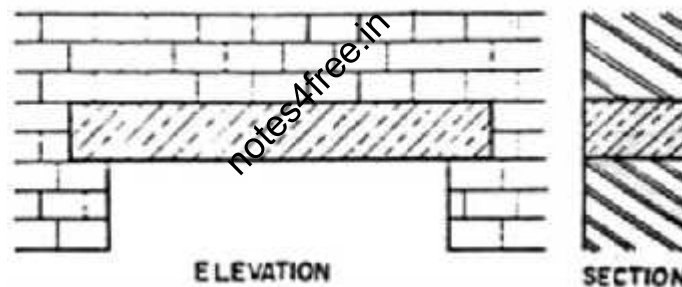

## 3. Brick lintels

- These are not structurally strong and they are used only when the opening is small (less than 1m) or loads are light.
- The thickness of brick lintel varies from 10 to 20cm depending upon the span.
- Bricks having frogs are more suitable for the brick lintels.
- It is because the frogs filled with mortar forms key (or joggles) between different layers and thus it increases the shear resistance of the end joint resulting in the increased strength of a lintel.

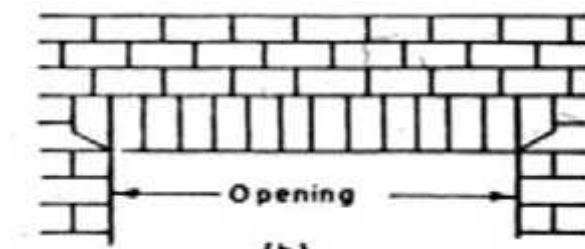

#### 4. Steel lintels

- These are provided where the opening is large and where the super-imposed loads are also heavy.
- These lintels consist of steel angles or rolled steel joints. The steel angles are used for small spans and light loading and rolled steel joints is used for large spans and heavy loading.
- A steel lintel is preferred when there is no space available to accommodate the rise of an arch.

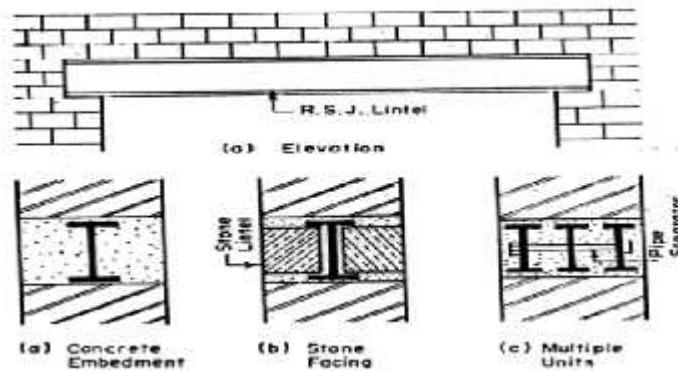

#### 5. Reinforced Cement Concrete Lintel

- At present, the lintels of R.C.C are widely used to span the openings for doors, windows, etc. in a structure because of their strength, rigidity, fire resistance, economy and ease in construction.
- R.C.C lintels are suitable for all the loads and for any span.
- The width of lintel is equal to width of wall.
- Depth of lintel is dependent of length of span and magnitude of loading.
- Main reinforcement is provided at the bottom and half of these bars are cranked at the ends. Stirrups are provided to resist transverse shear
- The usual concrete mix for R.C.C.lintel is 1:2:4 (cement: sand: agg)

##### Reinforcement for lintels for ordinary loading

The number of main bars for a lintel depends upon the load from wall to be carried above and the span of the opening. The diameter of bar varies with the span.

Upto 1.2m span – 10mm dia

1.2 to 2 span – 12mm dia

2 to 3m span – 16mm dia are used

##### 3.1.4 Method of construction

- Construct the brick wall up to the lintel bottom level.
- Construct the centering work. It may be wood and mud centering or steel centering.



- Depending upon the types of lintel, construct the lintel. Ex. If R.C.C. lintel, place the reinforcement cage on centering platform.
- Fix the side shuttering; Place the sheath covering all round the reinforcement cage.
- Pour the concrete. After 24 hours *remove* the shutters and cure it for about 28 days.

### 3.1.5 Questions

1. What is a lintel
2. What are types of lintels?
3. Explain the method of construction of lintels.

### 3.1.6 Outcome

- Able to study the lintels
- Able to know the types of lintels
- Able to know the method of construction of lintels

### 3.1.7 Future study

<https://www.slideshare.net/SARASWATIPATHARIYA/lintels-and-arches-in-construction>.

### 3.2.1 Chejja:

It is an extended position and thin slab above doors, windows and ventilators.

### 3.2.2 Objectives

To know about Chejja and its functions

### 3.2.3 Function

The Chejja gives protection to the opening space against rain water and direct sunlight. It is also called as weather shed.

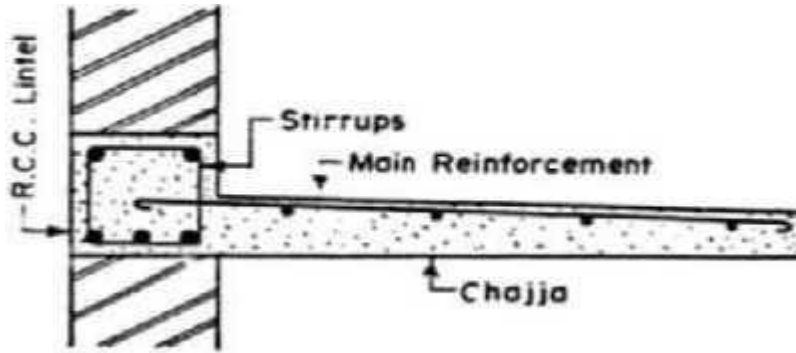

### 3.2.4 Types of Chejja

#### Based on material used

- RCC Chejja
- stone Chejja
- Tile Chejja
- Sheet Chejja
- Wooden Chejja( not so popular these days)
- FRP Chejja &
- Ferro-cement Chejja

### 3.2.5 Methods of construction

1. Centering plates are fixed at the chejja bottom level.
2. Reinforcement bars with proper cover blocks are placed on the centering plates.
3. Side shuttering is fixed
4. In the inner face of the side shuttering height of concrete at the wall side (say 100mm) as well as at the end of chejja (75mm) will be
5. Then the concrete will be laid and it will be cure for 28 days.

### 3.2.6 Questions

1. What is a Chejja?
2. What is the function of Chejja?
3. Explain the method of construction of Chejja.

### 3.2.7 Outcome

Gives knowledge about Chejja, function and method of construction

### 3.2.8 Future study

<http://nptel.ac.in/courses/107103002/9>

## Canopy or Portico

### 3.3.1 Introduction

A **canopy** is an overhead roof or else a structure over which a fabric or metal covering is attached, able to provide shade or shelter from weather conditions such as sun, hail, snow and rain. A canopy can also be a tent, generally without a floor.

## Balcony

A Balcony is a platform which is projected from wall of a building, constructed above ground floor, supported by columns or consoled brackets and enclosed within balustrade.

### 3.3.2 Objectives

To Know about Canopy, Balcony and its functions

### 3.3.3 Function of Canopy

Generally it is used for parking vehicles.

### Function of Balcony

- It is used for relaxation purpose.
- It gives a good architectural appearance to a structure.

### 3.3.4 Method of construction

1. Construct the walls up to roof level.
2. Centering is placed in front of that wall (outside the building) where portico or balcony is necessary.
3. The centering is supported by vertical members called jacks or woodenpoles.
4. These poles are in turn rests on the hard ground it is for portico or it should rest on 1<sup>st</sup> floor slab if the balcony is in 2nd floor.
5. Reinforcement bars are placed on these centering sheets and are properly tied using binding wires.
6. Finally concrete is laid to the sufficient thickness and properly cured for desiredperiod.

### 3.3.5 Questions

1. Briefly explain the terms used in arches?
2. Explain the types of arches lintels?
3. Explain the types of balcony?

### 3.3.6 Outcomes

Able to study the arches and lintels work

Able to distinguish arches and lintels work

Able to know the types of balcony, arches and lintels

### 3.3.7 Future study

<http://nptel.ac.in/courses/105105109/pdf/m5133.pdf>

## Arches

### 3.4.1 Introduction

An arch is a structure which is constructed to span across an opening. It generally consists of small wedge-shaped units which are joined together with mortar.

### 3.4.2 Objectives

- To study the terms used in arches
- To study the types of arches
- To gain the knowledge on uses of arches

### 3.4.3 Elements of an Arch

1. Intrados: This is the inner curve of the arch.
2. Extrados: This is the external curve of an arch.
3. Soffit: This is the inner surface of the arch.
4. Voussoirs: These are the wedge-shaped units forming the courses of an arch.
5. Skewback: This is the inclined or splayed surface on the abutment which is so prepared to receive the arch and from which the arch springs.
6. Crown: This is the highest point on the extrados.
7. Key: This is the wedge-shaped unit at the crown of an arch.
8. Springing points: These are the points from which the curve of an arch springs.
9. Springing line: It is an imaginary line joining the springing points of either end.

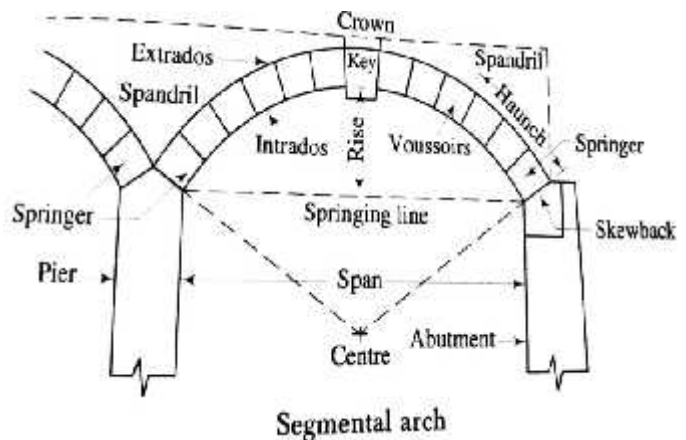

10. Abutment: This is the end support of an arch.
11. Piers: These are the intermediate supports of an arcade.
12. Span: This is the clear horizontal distance between the supports.
13. Rise: This is the clear vertical distance between the highest point on the intrados and the springing line.
14. Centre: This is the geometrical center of the curve of an arch.

### 3.4.4 Types of arches

The various types of arches can be classified as follows

1. According to shape
2. According to number of centers
3. According to workmanship
4. According to materials of construction

#### Classification of arches according to shapes

1. **Flat arch:** The apparent shape of this arch is flat and usually the skewback forms an angle of  $60^\circ$  with the horizontal. It forms an equilateral triangle with intrados as the base. The intrados is apparently flat, but it is given a slight rise of camber of about 10 to 15mm per meter width of opening to allow for small settlements. The extrados is kept horizontal and flat. These are used only for light loads and for spans up to 1.5m.

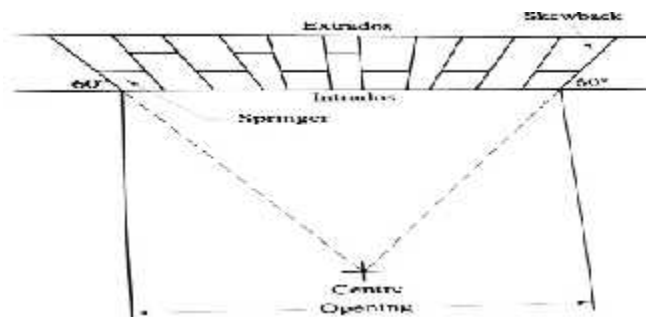

2. **Segmental arch:** This is the most common type of arch used for buildings. The center of arch lies below the springing line. The thrust transferred to the abutment is in an inclined direction.
3. **Semi-circular arch:** The center of the arch lies on the springing line and the shape of curve of arch is a semi-circle. As the skewback is horizontal, the thrust transfer red to the abutment is perfectly in vertical direction.

4. **Semi-elliptical arch:** The shape of the arch in semi-elliptical and it has more than one centre
5. **Horse shoe arch:** The arch has the shape of a horse shoe, incorporating more than a semi-circle, such type of arch is provided mainly from architectural considerations.

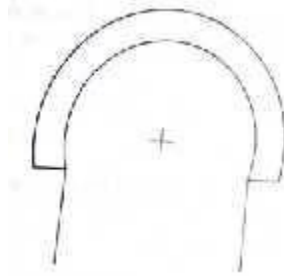

6. **Inverted arch:** This type of arch is provided in order to improve the bearing capacity of soil.

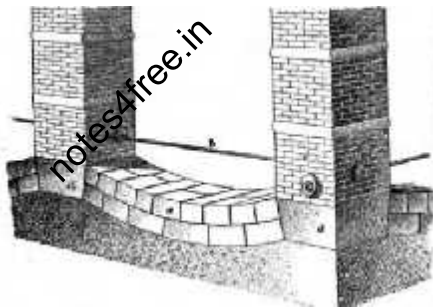

7. **Pointed or Gothic arch:** It consist two arcs of circles meeting at the apex. The triangle formed may be equilateral or isosceles (Lancet arch)

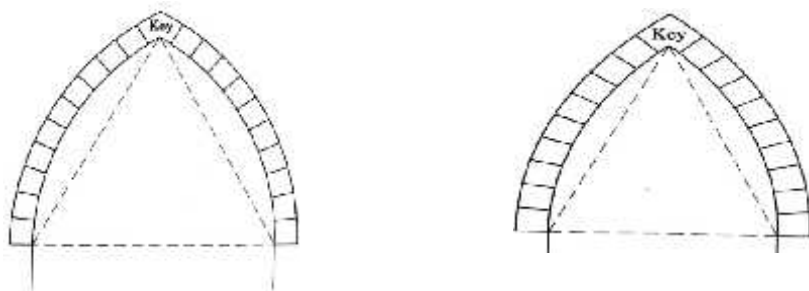

8. **Venetian arch:** This is another form of pointed arch which will have deeper depth at crown than at springing. It consists 4 centers, all located on springing line.

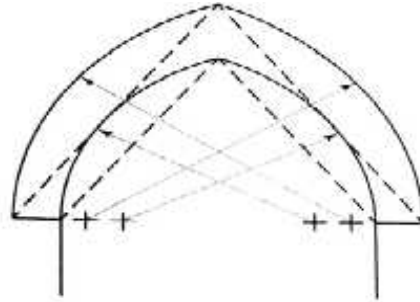

Venetian arch

9. **Florentine arch:** This is similar to Venetian arch except that the intrados is a semicircle. This will have three centers, all located on the springing line.

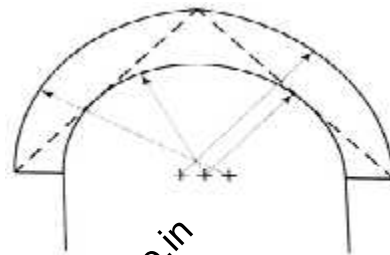

Florentine arch

10. **Relieving arch:** This arch is constructed either on a flat arch or on a wooden lintel to provide greater strength.

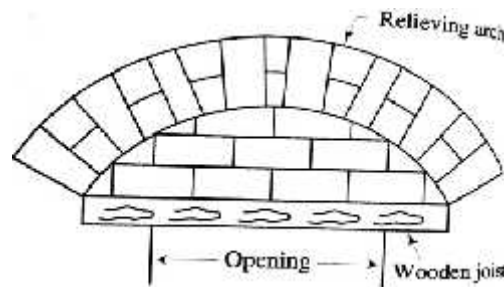

11. **Stilted arch:** It consists of a semicircular arch with two vertical portions at the sping.

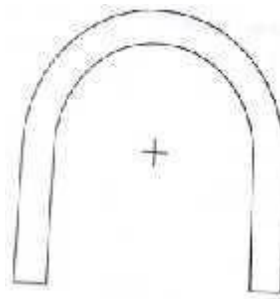

**Classification of arches according to number of centers**

1. **One centered arch:** Ex: Flat, Segmental, Semi-circular, horse shoe and stilled arches
2. **Two centered arch:** pointed arch
3. **Three centered arch:** Florentine arch
4. **Four centered arch:** Venetian arch
5. **Five centered arch:**

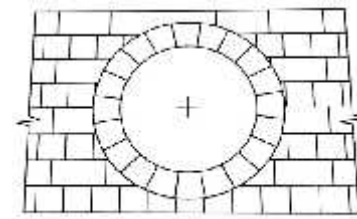

Bull's eye arch

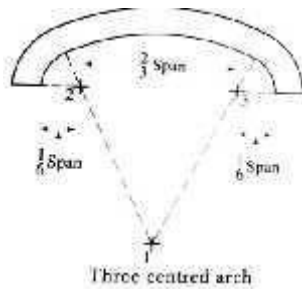

Three centered arch

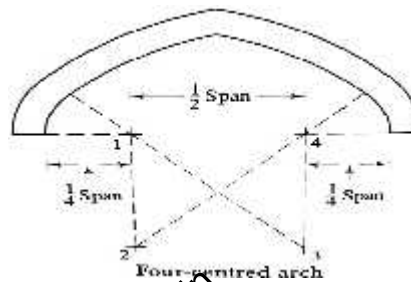

Four centered arch

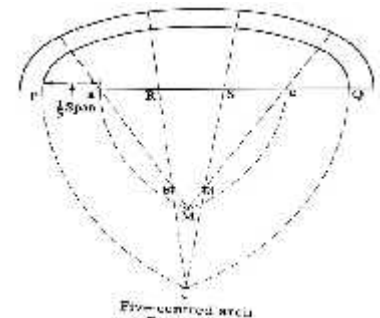

Five centered arch

**Classification of arches according to workmanship:**

1. **Rough arch:** This type of arch is constructed from ordinary uncut bricks. As the bricks are rectangular in shape the mortar joints become wider at the extrados than at the intrados.
2. **Axed or rough-cut arch:** This type of arch is constructed from bricks which are cut to a wedge-shape by means of an arc. The thickness of mortar joints varies from 3mm to 6mm.
3. **Gauged arch:** This type of arch is constructed from bricks which are finely cut by means of a wire saw. The mortar joints are as thin as 1.50mm to 0.75mm.

**Classification of arches according to materials of construction:****1. Stone arches:**

The arches can be constructed in the rubble masonry or ashlar masonry. The rubble masonry arch is comparatively weak and hence it is used for inferior type of work.

**2. Brick arches:**

These arches can be constructed from ordinary bricks or purpose made bricks. The ordinary bricks are not cut to the shape of voussoirs and hence the rough brick arches are formed. For getting the arch curve, the joints are made wedge shaped with greater thickness at the extrados and smaller thickness at the intrados.



### 3. Concrete arches:

These arches can be constructed of the precast cement concrete blocks or monolithic concrete. The blocks are similar to stones and are prepared by casting cement concrete in specially prepared moulds. The monolithic concrete arches are constructed from cast in-situ concrete and suitable for big spans.

#### 3.4.5 Stability of an arch

An arch transmits the superimposed load to the abutments or piers or side walls through the combined action of friction between the surfaces of voussoirs and the cohesion of mortar.

Following are the four ways of failure of an arch:

1. Crushing of the masonry
2. Rotation of some joint about an edge
3. Sliding of voussoir.
4. Uneven settlement of abutment or pier.

#### 1. Crushing of the masonry:

- In this case, the compressive stress or thrust exceeds the safe crushing strength of the materials and the arch fails due to crushing of the masonry.
- The measures to avoid failure of arch due to this reason are as follows:
- The material used for construction should be of adequate strength.
- The size of voussoirs should be properly designed to bear the thrust transmitted through them.
- If necessary the voussoirs of variable heights may be provided i.e less height near crown and max height at skewback.

#### 2. Rotation of some joint about an edge:

To prevent the rotation of joint, the line of resistance should be kept within intrados and extrados. The line of thrust should also be made to cross the joint away from the edge so as to prevent the crushing of that edge. It should fall within the middle third portion of the archheight.

#### 3. Sliding of voussoir:

To safeguard against the sliding of adjacent voussoirs due to transverse shear, the voussoir of greater height should be provided.

#### 4. Uneven settlement of abutment or pier:

The secondary stresses in the arch are developed due to the uneven settlement of the supports of arch and to avoid such conditions, the following precautions should be taken

- The arch should be symmetrical so that unequal settlements of the two abutments or abutment and pier are minimized.
- The supports of arch should be strong enough to take or resist the thrust as well as to bear all the loads transferred to them through the arc.

### 3.4.6 Questions

1. What is an arch?
2. What are the types of arches?
3. Write a note on stability of an arch.

### 3.4.7 Outcome

- Able to study the arches
- Able to distinguish arches
- Able to know the types of arches.

### 3.4.8 Future study

<http://nptel.ac.in/courses/105105109/32>

notes4free.in

## ROOFS AND FLOORS

### Structure

- 3.5.1 Introduction
- 3.5.2 Objective
- 3.5.3 Classification of Roofs
- 3.5.4 Sloped Roof or Pitched roof
- 3.5.5 Flat Roof
- 3.5.6 Wooden truss
- 3.5.7 Steel truss
- 3.5.8 Roof Coverings
- 3.5.9 Flooring
- 3.5.10 Selection of Flooring Material
- 3.5.11 Types of Flooring
- 3.5.12 Outcomes
- 3.5.13 Questions
- 3.5.14 Future Study

notes4free.in

## Roofs

### 3.5.1 Introduction

A roof is defined as the upper most part of a building, provided as a structural covering, to protect the building from weather. The structural elements may be trusses, portals, beams, slabs, shells or domes and the roof coverings may be A.C. sheets, G.I. sheets, wooden shingles, tiles, slates etc.

### 3.5.2 Objectives

- To study the terms used in roofs and floors
- To study the types of roofs and floors
- To gain the knowledge on wide uses of types of roofs and floors based on economy as well as the requirement

### Requirements of good roof

- It should be durable against adverse effects
- It should withstand the load
- It should be a perfect insulator
- It should be well-drained
- It should have better water-proofing arrangement

notes4free.in

### 3.5.3 Classification of Roofs

1. Flat roofs or terraced roofs
2. Pitched or sloping roofs
3. Curved roofs

### 3.5.4 Sloped Roof or Pitched roof

- A roof with sloping surface is known as a pitched or sloped roof. These roofs suitable for buildings in coastal regions or in areas where in rainfall are very heavy.
- Buildings with limited width and simple shape can generally be covered satisfactorily by pitched roofs.
- The slope varies according to span, climatic condition, and nature of covering materials.

**Elements of a Pitched roof**

**Types of pitched roofs**

**1. Single roofs**

Single roofs consist of only common rafters which are secured at the ridge (to ridge beam) and wall plate. These are used when span is less so that no intermediate support is required for the rafters.

➤ **Lean-to-roof**

- This is the simplest type of sloping roofing in which rafters slope to one side only it is also known as the pent roof or Aisle roof
- In this type one wall is carried up sufficiently higher than the other one to give necessary slope to roof.
- A wooden wall plate is supported either on a steel corbel or a stone corbel which may be of stone, brick or steel.
- A lean to roof is generally used for sheds, out-houses attached to main buildings, verandahs etc. it is suitable for a maximum span of 2.40m.

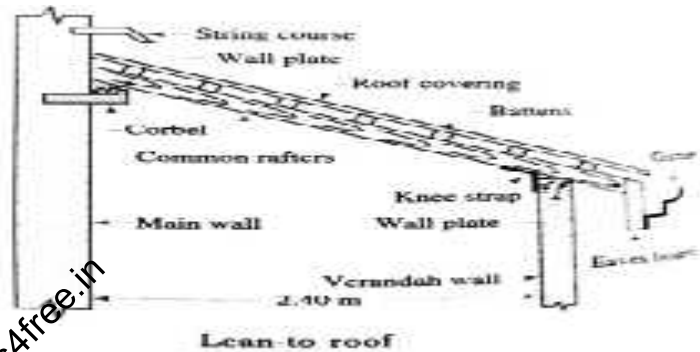

➤ **Couple roof**

This type of roof is formed by couple of rafters which slope to both the sides of the ridge of the roof. The upper ends of each pair of rafter is nailed to a common ridge piece and their lower ends are notched and nailed to the wooden wall plates embedded in the masonry on the top of the outer walls. Such a roof is not very much favored because it has the tendency to spread out at the feet and thrust out the walls supporting the wall plates due to this, the couple roof is used when the span is limited to 3.6m.

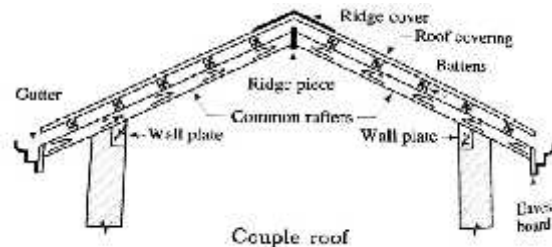

➤ **Couple-close roof**

This roof is similar to the couple roof except that the ends of the couple of common rafters is connected by horizontal member called tie beam to prevent tie rafters from spreading and thrust out of tie wall. The tie beam may be a wooden member or a steel rod. These are one tie beam for each pair of rafters. A couple close roof can be adopted economically up to

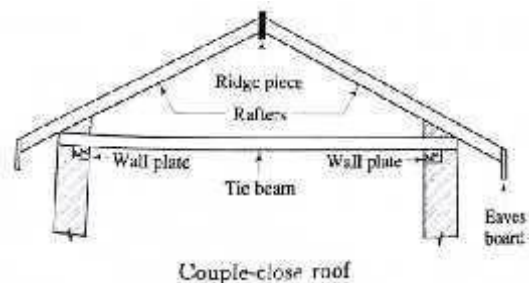

a span of 4.2 m.

### ➤ Collar Beam roof

When tie span increases or when tie load is more tie rafters of tie couple close roof have tie tendency to bend. This is avoided by raising the tie beam and fixing it at one third to one half of tie vertical height from wall plate to tie ridge. This raised beam is known as tie collar beam. Thus a collar beam roof is similar to a close couple roof except that in the couple close roof a tie beam is provided at tie level of wall plates while in tie collar beam roof, tie beam is provided at raised level. This roof is suitable for spans up to 4.8m. A collar beam is adopted to economies tie space and to increase tie height of a room.

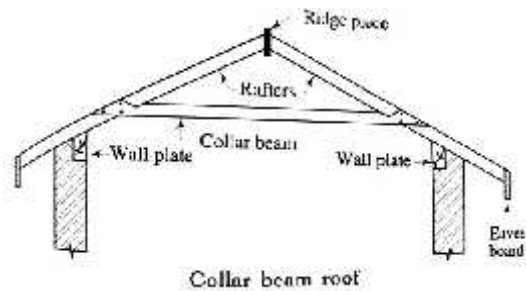

### ➤ Collar and Scissor roof

This roof is similar to the collar beam roof except that two collar beams which are crossing each other to present an appearance of scissors are provided as shown in fig.

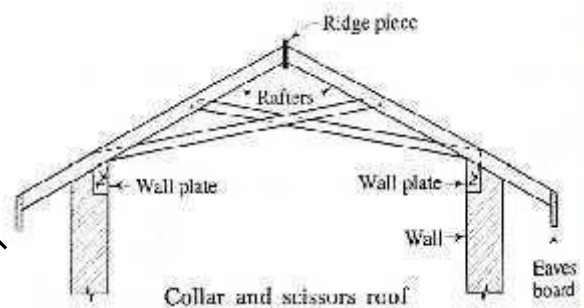

## 2. Double or purlin roofs

## 3. Triple membered or framed or trussed roofs

When the span of the roof exceeds 5m and where there are no inside supporting walls or partitions for the purlins, framed structures known as the trusses are provided at suitable interval along the length of the room. The spacing of trusses depends upon the load on the roof, position of cross walls, span and material of the truss. Spacing is generally limited to 3 meters for wooden trusses.

Thus the roof in this system consists of the following three components:

1. Rafters to support the roofing material.
2. Purlins to provide intermediate support to the rafters and
3. Trusses to grant support to the ends of purlins

### 3.5.5 Types of Trussed roofs

#### ➤ King-post roof truss

A king post truss consists of following components.

1. Lower tie beam
2. Two inclined principal rafters

3. King post
4. Two struts

In this type of truss tie central post is known as king post forms a support for the tie beam. The principal rafters support the purlins. The purlins support the closely spaced common rafters which have the same slope as the principal rafters. The common rafters support the roof covering as usual. A king post truss is suitable for roofs of span varying from 5m to 8m. The spacing of the king post truss is limited to 3m center to center. The lower horizontal tie beam receives tie ends of tie principal rafters and prevents tie wall from spreading out due to thrust. The king post prevents the tie beam from sagging at its center of span. Tie struts connected to the tie beam and the principal rafters in inclined direction prevent the sagging of principal rafters. Ridge beam is provided at the apex of the roof to provide end support to the common rafters.

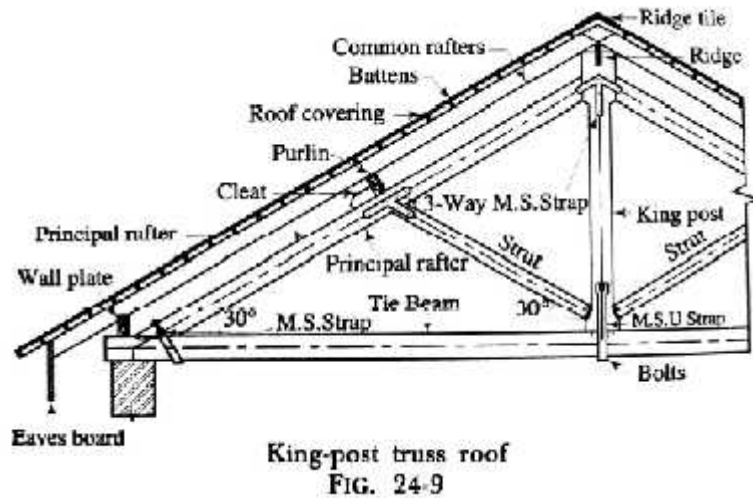

Joints in this truss are:

1. Joint between the principal rafter and tie beam
2. Joint between the king post and tie beam
3. Joint at the head and feet of strut.
4. Joint between the principal rafters and the King post

➤ **Queen-post roof truss**

A queen post truss differs from a king-post truss in having two vertical posts, rather than one. The vertical posts are known as queen-posts, the top of which are connected by a horizontal piece, known as straining beam. Two struts are provided to join the feet of each queen post to the principal rafter.

The queen posts are the tension members. A straining sill is introduced on the beam between the queen posts from inclined struts which are in compression. In absence of the straining sill, the thrust from the strut would tend to force the foot of the queen post inwards. Purlins with cleats are provided as in the king post truss. These trusses are suitable for spans

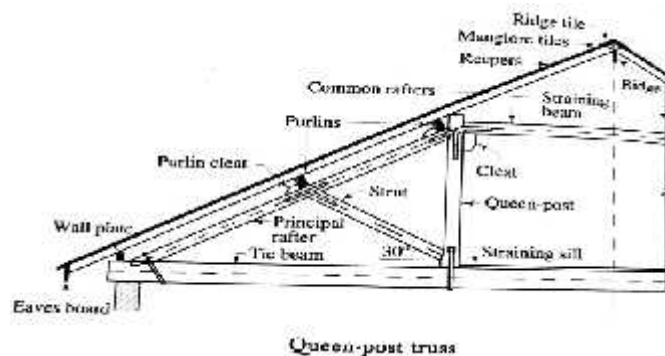

between 8 to 12m.

Joints in this truss are:

1. Joint at the head of queen post
2. Joint at the feet

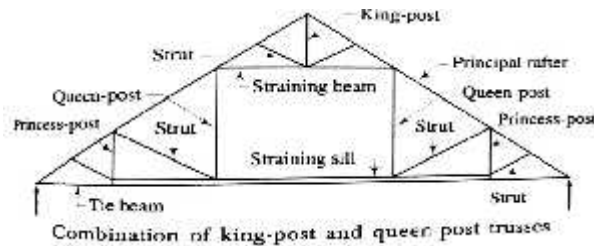

### 3.5.6 Steel truss

#### ➤ Steel sloping roof trusses

When the span exceeds 10m, timber trusses become heavy and uneconomical. Steel trusses are more economical for larger spans. However steel trusses are more commonly used these days for all spans small or large since they are more economical, ease to construct, more rigid, fire proof and permanent.

Steel trusses are fabricated from rolled steel structural members such as channels, angles, T-sections and plates. Most of the roof trusses are fabricated from angle-sections because they can resist effectively tension as well as compression and their jointing is easy.

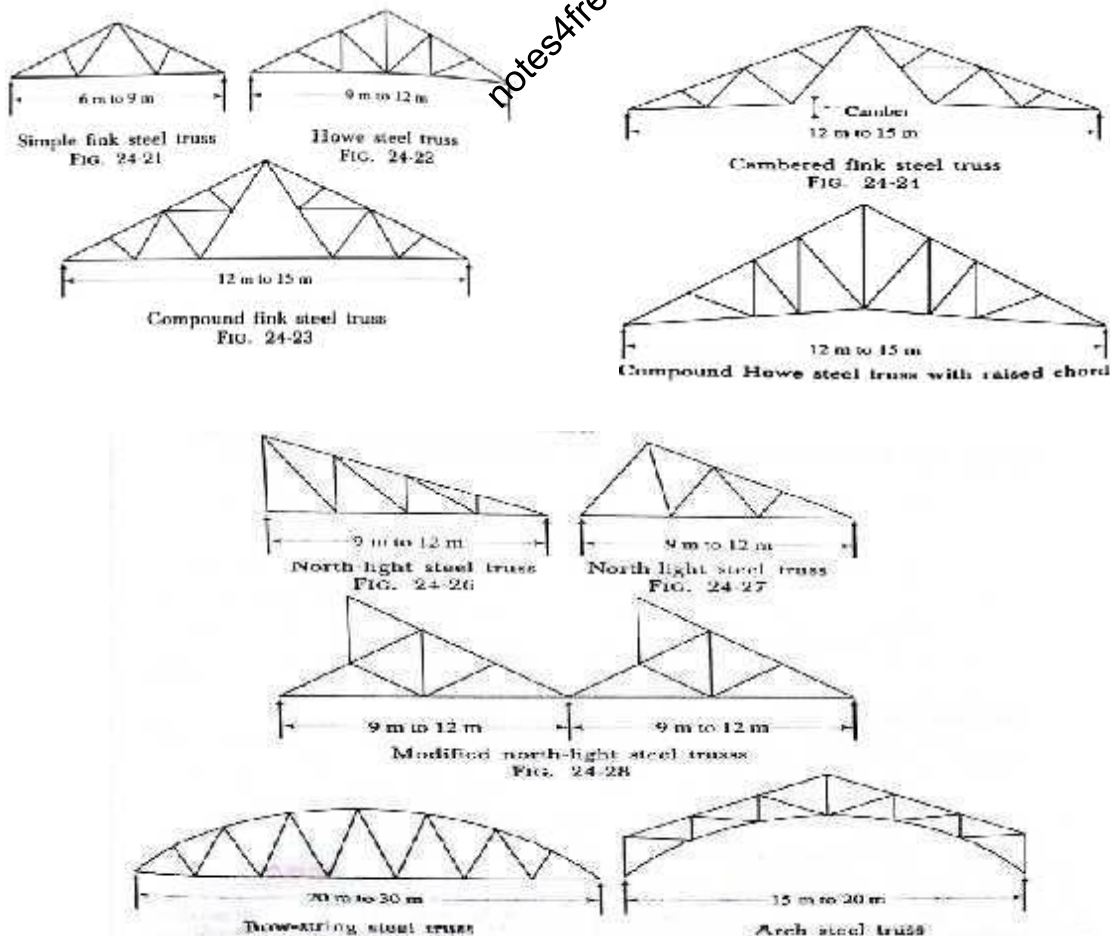



- Combination of Kingpost and Queen post truss
- Mansard roof truss
- Truncated roof truss Or latticed roof truss
- Composite roof trusses

### 3.5.7 Flat Roof

- Flat roof is the one which is either horizontal or practically horizontal with slope less than  $10^\circ$ , so that rain water can be drained off easily and rapidly.
- The construction is same as that of floors except the top surface is made slightly sloping. It may be of RCC, reinforced brick work, precast concrete units etc.
- Flat roofs are considered suitable for buildings in plains or in hot regions, where rainfall is moderate and where snowfall is not there.
- Efficient water proofing and road drainage is an important requirement of flat roof. In addition insulating material layer is provided for thermal insulation which is known as terracing or grading. Usually 1 in 40 to 1 in 60 slopes is provided for RCC roofslab.

### Advantages of Flat Roof

1. The construction of roof is simple, Maintenance is easier.
2. The roof can be used as terrace for playing, gardening, sleeping and for celebrating functions.

### Disadvantages of Flat Roof

- Their span is restricted and cannot be used for large spans without the introduction of intermediate columns and beams.
- The dead weight of flat roof is very high and hence is more expensive. Its initial cost is higher than a pitched roof.
- They are unsuitable at places of heavy rainfall

### 3.5.8 Roof coverings

Roof coverings is a material covering provides over the form work of roof structure to act as a barrier against the atmospheric agencies. The selection of covering material depends upon various factors such as

1. Climate of the locality
2. Initial cost and maintenance cost
3. Durability
4. Availability of material
5. Nature of building
6. Fabrication facilities
7. Type of roof frame work.

## 8. Special features of the locality

### **Thatch Roofs**

- Light roof covering
- Combustible
- Absorbs moisture
- Liable to decay
- Unstable for high winds
- Used in rural areas because it is cheaper to construct

### **Ordinary Half-round Country tiles**

- Used for low cost houses
- Liable to breakage
- Frequent maintenance

### **Shingles**

- Used adopted in hilly areas

### **Patent tile roofs**

- Mangalore tiles are one of such patent tiles.

### **Trafford asbestos-cement tiles**

- Made up of cement and asbestos material.
- They possess less corrugations

### **Eternit slates**

- They have good Fire resisting property
- They are light in weight and provide cool environment.
- Less affected by weather

### **Corrugated Galvanized Iron sheets**

- Prepared by pressing wrought iron sheets by rollers with grooves or teeth.
- They are coated with zinc.
- They are costly and do not offer resistance to fire and sound.

### **Asbestos-cement corrugated sheets**

- The cement is mixed with 15% of asbestos fibers and paste so formed is pressed under rollers with groove or teeth.
- They are cheap, Light in weight, Fire resisting
- Strong, tough, sound-proof, impervious and durable

### RCC Roof

Elements of RCC slab are

- Cement
- Coarse Aggregate
- Fine aggregate
- Mild Steel Bars
- Binding Wires
- Water
- Shuttering materials such as wooden planks, iron sheets.

### 3.5.9 Flooring

The solid construction between the plinth level and roof level are known as floors and the exposed top surfaces of floors are termed as floorings.

Components of a floor:

A floor is composed of two components:

- i. Sub-floor, base course or floor base
- ii. Floor covering or simply, flooring.

### 3.5.10 Selection of Flooring Material

Following factors are to be carefully considered before selecting the material for flooring of a particular building

1. Appearance
2. Cleanliness
3. Cost
4. Damp resistance
5. Durability
6. Fire resistance
7. Hardness
8. Maintenance
9. Thermal Insulation
10. Slipperiness

- **Appearance:** covering should give pleasing appearance; it should produce a desired color effect and architectural beauty. Floorings of terrazzo, mosaic, tiles and marble give good appearance.
- **Cleanliness:** The flooring should be capable of being cleaned easily, and it should be non-absorbent. It should have effective resistance against absorption of oil, grease etc.
- **Cost:** the cost of the material should be in conformity with the type of building, and its likely use. Floor coverings of marble etc are very costly and may be used only for residential buildings.
- **Damp resistance:** Flooring should offer sufficient resistance against dampness, so that healthy environment is obtained in the building. Flooring of concrete, terrazzo, mosaic etc are preferred for this purpose, while flooring of wood, rubber etc are preferred for this purpose, while flooring of wood, rubber, etc are not suitable for damp conditions.
- **Durability:** The flooring should have sufficient resistance to wear, temperature changes, disintegration with time and decay so that long life is obtained. From this point of view, flooring of marble, terrazzo, concrete etc are considered to be of best type.
- **Fire resistance:** This is more important for upper floors. Flooring material should offer sufficient fire resistance so that fire barriers are obtained between different levels of a building.
- **Hardness:** It should be hard so as to have resistance to indentation marks, imprints etc likely to be caused by shifting of furniture, equipment etc.
- **Maintenance:** the flooring material should require least maintenance. However, whenever repairs are required, it should be such that repairs can be done easily with least possible expenditure.
- **Thermal insulation:** the flooring should offer reasonably good thermal insulation so that comfort is imparted to the residents of the building.
- **Slipperiness:** The surface of floor should be smooth but at the same time, it should not be too slippery.

### 3.5.11 Types of flooring

In order to give a pleasing appearance to the upper surface of the floor, the various materials are placed on it. It is used to provide for ground floor. The materials used for floor finish or floor covering or flooring are:

1. Granolithic finish
2. Mosaic
3. Ceramic
4. Marble
5. Polished Granite
6. Industrial flooring
7. Wood or timber
8. Asphalt

9. Glass
10. Linoleum flooring
11. Cork
12. Rubber etc.

### **1. Granolithic finish:**

In industrial building, hard wearing surface is sometimes required. This can be achieved by applying granolithic finish over the concrete topping. The topping consists of 1:2:4 cement concrete, laid to the desired thickness in one single operation in the panel. Alternate panels are laid first prior to laying the concrete in the panel a coat of neat cement slurry is applied. This cement slurry laid on rough finished base course ensures proper bond of topping with the base course. Granolithic finish consists of rich concrete made with very hard and tough quality coarse aggregate graded from 13mm IS sieve. The concrete mix proportion varies from 1:1:2 to 1:1:3 for heavy duty floors to 1:2:3 for public buildings. The thickness of finish may be minimum 25mm when laid monolithically with the top concrete and 35mm when laid over hardened surface. However for public buildings such as schools hospitals etc. the thickness of the finish may be 13mm to 20mm.

### **2. Mosaic Flooring:**

Mosaic flooring is made of small pieces of broken tiles of china glazed or of cement or of marble arranged in different pattern. These pieces are cut to desired shapes and sizes. A concrete base is prepared as in the case of concrete flooring. The base course of concrete flooring may be 7.5 to 10cm thick, either in lean cement concrete or lime concrete containing 40% mortar of 1:2 lime sand and 60% coarse aggregate of 40mm nominal size. The base course is laid over well compacted soil, compacted properly and leveled to rough surface. It is properly cured and over it 5 to 8cm thick lime surkhi mortar is spread and leveled over an area which can be completed conveniently within working period so that the mortar may not get dried before the floor is finished. On this a 3mm thick cementing material, in the form of a paste of two parts of slaked lime

### **3.5.12 Questions**

1. Briefly explain the terms used in roofs and floors?
2. Explain the types of roofs and floors?
3. Explain the uses of roofs and floors?

### 3.5.13 Outcomes

- Able to study the roofs work
- Able to distinguish different types of roofs
- Will be knowing the types of and uses of floors

### 3.5.14 Future Study

[https://www.vssut.ac.in/lecture\\_notes/lecture1424085991.pdf1](https://www.vssut.ac.in/lecture_notes/lecture1424085991.pdf1)

notes4free.in

**Module – 4**

**Doors, Windows and Ventilators**

**Structure**

4.1.1 Introduction

4.1.2 Objective

4.1.3 Important considerations for Doors

4.1.4 Technical terms

4.1.5 Types of Doors

4.1.6 Windows

4.1.7 Types of Windows

4.1.8 Ventilators

4.1.9 Questions

4.1.10 Outcomes

4.1.11 Future study

notes4free.in

### 4.1.1 Introduction

A door may be defined as an openable barrier secured in a wall opening. It serves as a connecting link between the various internal partitions of a building.

Basically a door consists of two parts

1. Frame
2. Shutter

### 4.1.2 Objectives

- 1) To study the terms used in doors and windows
- 2) To study the types of doors and windows
- 3) To gain the knowledge on wide uses of types of doors and windows

### 4.1.3 Important considerations for Doors

#### I. Location of Doors

- A. The location of a door should meet functional requirements of ROOM. It should not be located in the centre of the length of wall. A door should preferably be located near the corner of a room, nearly 20cm away from the corners.
- B. The number of doors in a room should be kept minimum due to the fact that more number of doors will cause obstruction and reduce the effective usable carpet area of the room.
- C. If there are two doors in a room, the doors should preferably be located in opposite walls, facing each other, so as to provide good ventilation and free air circulation in the rooms.

#### II. Size of Doors

The size of a door should be such that it would allow the movement of largest object or tallest person likely to use the door.

The common width-height relations, used in India are

1. Width=0.4 to 0.6 height
2. Height = (width-1.2) meter

The following are the generally adopted sizes of doors for various types of buildings. Doors of residential buildings

1. External door- (1.0 m x2m) to (1.1 x 2m)
2. Internal doors-(0.9m x 2m) to (1m x 2m)
3. Doors for bathrooms and water closets-(0.7m x 2m)to (0.8m x 2m)
4. Garages for cars-2.25m x 2.25m



5. Doors of public buildings like school, hospitals, library etc-1.2m x 2.0m

#### 4.1.4 Technical terms

1. **Frame:** This is an assembly of horizontal and vertical members, forming an enclosure, to which the shutters are fixed.
  2. **Shutters:** The entire assembly of styles, panels and rails is known as the shutters. **Style:** It is the outside vertical member of the shutter of a window.
  3. **Head:** The top or uppermost horizontal part of frame is known as head.
  4. **Top rail:** This is the top most horizontal member of a shutter.
  5. **Lock rail:** This is the middle horizontal member of a door shutter to which locking arrangement is fixed.
  6. **Bottom rail:** This is the lowermost horizontal member of the shutter.
  7. **Panel:** This is the area of shutter enclosed between the adjacent rails.
  8. **Horn:** These are the horizontal projections of the head and sill of a frame to facilitate the fixing of the frame on the wall opening. The length of horns is kept about 10 to 15cm.
  9. **Holdfast:** This is generally in holdfasts are the form of a mild steel flat bar of section 30mm x 6mm and of length 200mm. The three numbers of such hold fasts are provided on each side of the door frame and two numbers of such holdfasts are provided on each side of the window-frame. They keep the frame position.
  10. **Rebate:** The depression made inside the door frame to receive the door shutter is known as the rebate.
11. **Mullion**
12. **Putty**

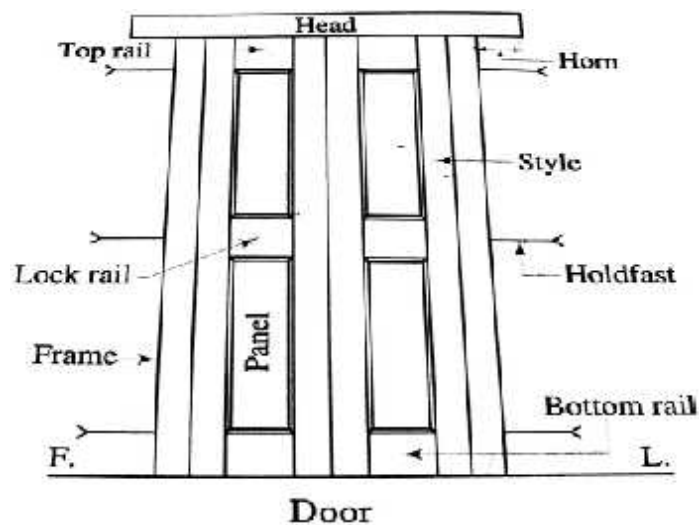

**4.1.5 Types of Doors**

Doors commonly used in building are classified into following types, depending upon For small opening a door is provided with one leaf or shutter and such a door is known as Single leaf door. In case of wider opening the door should have twp leaves and such a door is termed as double leaf door.

**Framed and Paneled door**

These types of doors are widely used in almost all types building since they are strong and give better appearance compared to other types of doors. This door consists of a framework of vertical members (called styles) and horizontal members, called rails which are grooved along the inner edges of the frame, to receive the panels. The panels are made from timber, black board, or glasses. Various forms of paneled doors are as shown in fig. in which the doors can have one panel, two panels or multiple panels.

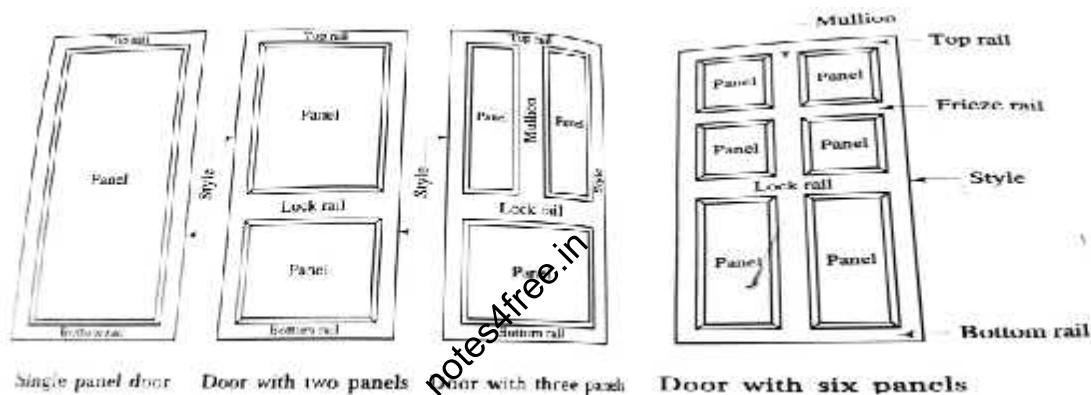

**Glazed or Sash Doors**

In order to admit more light, in addition to that coming from the windows, the fully glazed or partly paneled and partly glazed doors are used. In the partly glazed and partly paneled case, the ratio of glazed portion to paneled portion is kept 2:1, the bottom one-third height is paneled and the top two-third height is glazed. The glass is received into rebates provided in the wooden sash bars and secured by “rails putty” or by wooden beads fixed to the frame.

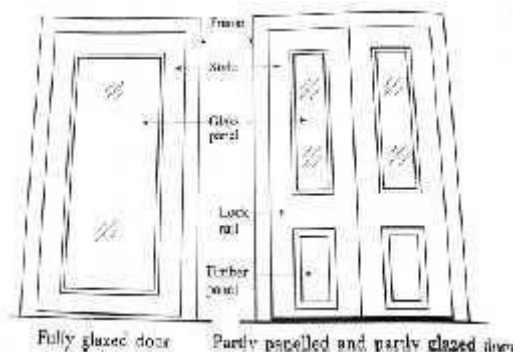

**Flush Doors**

With the large scale production of plywood flush doors are becoming increasingly popular these days, because of their pleasing appearance, simplicity of construction, less cost, better strength and greater durability. They are used both for residential as well as public and commercial buildings.

These doors consist of solid or semi-solid skeleton (core) covered on both sides with plywood, face veneers etc, presenting flush and joint less surface which can be neatly polished.

**Flush doors are of two types:**

Solid core flush door or laminated core flush door. Hollow and cellular core flush doors



### Collapsible and Rolling shutters

Such doors are used in go downs, workshops, sheds, public buildings etc, for providing increased safety and protection to property. Collapsible steel doors are commonly recommended in situations where light and ventilation are desired even when the opening is closed. It acts like a steel curtain which can be opened or closed by horizontal flush. The door is fabricated from vertical double channels (20 x 10 x 2 mm) joined together with the hollows on the inside,, so that a vertical gap is created. Such channel units are spaced at 100 to 120mm apart and are braced with flat iron diagonals 10 to 20mm wide and 5mm thick. These diagonals allow the shutter to open out or get closed. The shutter operates between two iron rails of T-shape, one fixed to the floor and other to the lintel. Rollers mounted on horizontal piece are provided both at the top and the bottom ends of vertical pieces.

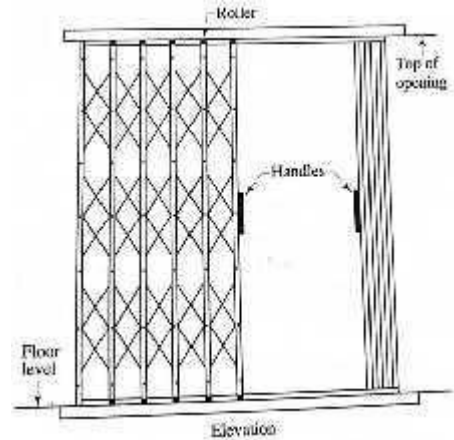

### Rolling Steel Shutter Doors

These doors are commonly used for garages, go downs, shops fronts show windows etc, since they are quite strong and offer proper safety to the property. The doors consists of a frame, a drum and a shutter of thin steel plates (known as laths or slates), about 1 to 1.25mm thick and inter locked together. The frame has steel guides on the sides in which the shutter moves and then coils in the drum. The diameter of the drum varies from 200 to 300mm. A horizontal shaft and springs are provided in the drum, due to which the shutter is opened or closed by small push or pull.

Rolling shutters are of two types

- i. Pull-push type shutters
- ii. Mechanical gear type shutters

When the area of door opening does not exceed 10 m<sup>2</sup>, the door shutter can be easily opened or closed by pushing it up or down manually. The door in such a case is known as push pull type rolling shutter door.

When the area of door opening is more than 10 m<sup>2</sup> the shutter is generally opened or closed by means of reduction gear operated by connecting rod and winding handle or by means of chain pulley blocks. The door in such a case is known as mechanical type rolling shutter door.

### Louvered doors (Venetian Doors)

Louvered doors permit free ventilation through them, and at the same time maintain the privacy of the room. In this type of doors, the shutters are provided with louvers, either fully or partly. The louvers are arranged at such an inclination that vision is obstructed while they permit free passage of air. This is achieved by fixing the upper back edge of a louver higher than the lower front edge of the louver just above it. The louvers may be movable or fixed. In case of movable louvers, a vertical piece of timber is provided to which the

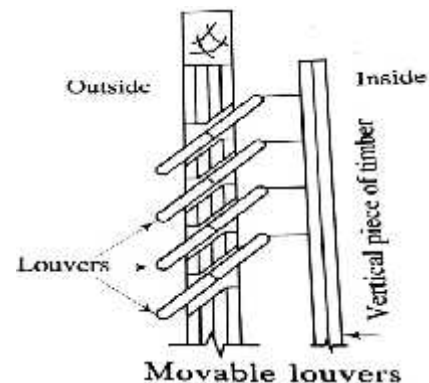

louvers are attached through hinges. The movement of louvers is actuated by the vertical piece of timber.

Louver may be made of either timber or glass or plywood. They are used for sanitary blocks of public buildings, residential buildings etc.

## **Revolving Doors**

A revolving door essentially consists of a centrally placed mullion or pivot in a circular opening. The revolving shutter or leavers which are four in number are radially attached to the pivot.

The shutter may be fully glazed, fully paneled or partly paneled and partly glazed. The central pivot is provided with ball bearing at the bottom and bush bearing at the top so that its rotation is smooth and without any jerk, friction and noise. At the rubbing ends of shutter, the vertical rubber piece is provided which prevent a draught of air. The arrangements are made such that the shutter can be folded when traffic is more and the opening can be locked when not in use.

A revolving door simultaneously provides entrance on one side and exit on the other end. It keeps the opening automatically in closed position, when not in use. It also grants protection against the wind brought and it is therefore found to be of much help at places subjected to strong winds during most of the part of the year. They are provided in big hotels, banks, offices, theatres, hospitals etc.

## **Sliding doors**

In this type of doors, the shutter slides on the sides with the help of runners and guide. The shutter may be of one or several leaves and can slide either on one side or both the sides. The cavities may be provided in the wall to receive the door in an open position or it may simply lie touching the wall.

A sliding door does not cause any obstruction during movement and is used for entrances of godowns, sheds, shops etc.

## **Swing Doors**

A swing door is provided with special hinges known as the double action hinges and thus the shutter of the door are held in closed position when the door is not in use.

As the return of the shutter is with force, it is desirable to provide glazed shutter of or alternatively a peep hole should be provided at the eye level to avoid the accident to the door users. The closing edge of the meeting styles should not be rebated and they should be made segmental. This type of door is widely used in passages of public buildings such as govt. offices, banks etc. When the door is to be used, a slight push is made and then the action of spring brings the shutter in closed position.

## Windows

### 4.1.6 Introduction

A window may be defined as an opening made in a wall for the purpose of providing day light, vision and ventilation. Construction of window is identical to that of door. It is comprised of two parts. 1) Frame 2) shutter. They are normally provided with two leaves.

The selection of size, shape, location and the number of windows to be provided in a room depends upon the following considerations.

- i. Size of the room
- ii. Location of the room and its utility
- iii. Direction of wind
- iv. Climatic considerations of the site such as humidity, temperature, variation etc. Architectural treatment to the exterior of the building

**Based on the above factors, the following thumb rules are in use:**

1. Breadth of windows =  $\frac{1}{8}(\text{width of room} + \text{ht of room})$
2. The total area of window opening should normally vary from 10 to 20% of the floor area of the room depending upon climatic conditions.
3. For sufficient natural light, the area of glazed panels should at least be 8 to 10% of the floor area.

### 4.1.7 Types of Windows

Depending upon types of materials used, nature of operational movements of the shutter, location and the manner in which they are fixed, windows can be broadly classified as under

1. Fixed windows
2. Bay windows
3. Dormer windows
4. Pivoted windows
5. Glazed windows
6. Sliding windows
7. Corner windows
8. Casement windows
9. Double hung window

#### Glazed windows or Sash Windows

A glazed window is a type of window in which the panels are fully glazed. The frame of each shutter consists of two vertical styles, top rail and a bottom rail. The space between the top and bottom rails is divided into small panels by means of small timber members placed horizontally and vertically. These timber members known as mullion. Similarly, if the height of window



opening is more the window frame may have horizontal member called transom.

### Bay Window

Bay windows project outside the external wall of the room. This projection may be triangular, circular, rectangular and polygonal in plan. Such an window provides an increased area of opening for admitting greater light and air. They also provide extra space in the room and improve the overall appearance of the building.



### 4.1.8 Ventilators

Ventilators are small size windows in which panels are fully glazed and provided with steel rods for the purpose of protection usually provided above the doors and windows in order to admit more light and air to the room.

It is not mandatory to provide above the windows and anywhere else but it should be provided in between lintels and ceiling.

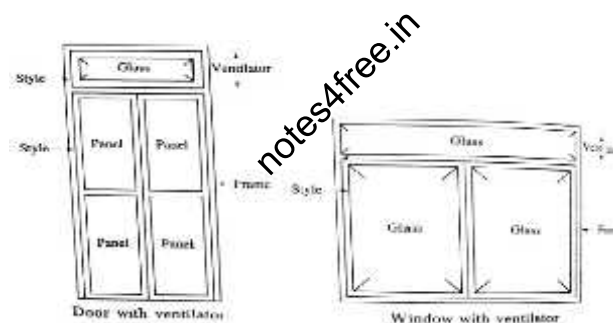

### 4.1.9 Questions

- Briefly explain the terms used in doors and windows?
- Explain the types of doors and windows?
- Explain the uses of doors and windows?

### 4.1.10 Outcomes

- Able to study the terms related to doors and windows
- Able to distinguish different types of doors and windows
- Will be able to know the types of doors and windows.

### 4.1.11 Future Study

## **STAIRS**

### **STRUCTURE**

4.2.1 Introduction

4.2.2 Objectives

4.2.3 Technical terms

4.2.4 Types of Stairs (Classification)

4.2.5 Requirements of a good stair

4.2.6 Questions

4.2.7 Outcomes

4.2.8 Future Study

notes4free.in

### 4.2.1 Introduction

- A stair may be defined as series of steps suitably arranged for the purpose of connecting different floors of a building.
- It may also be defined as an arrangement of treads, risers, and stringers, handrails so designed and constructed as to provide an easy and quick access to the different floors, rendering comfort and safety to the users.
- The room or enclosure of the building, in which the stairs is located, is known as stair-case. The opening or space occupied by the stair is known as stairway.
- Stairs may be made from various materials like timber, stones, bricks, steel, plain concrete or reinforced concrete.

### 4.2.2 Objectives

- To study the terms used in Stairs
- To study the types of stairs
- To gain the knowledge on wide uses of stairs

### 4.2.3 Technical terms

1. **Baluster:** It is the vertical member of wood or metal, supporting the hand rail.
2. **Flight:** It is defined as an unbroken series of steps between the landings.
3. **Going of step:** It is the horizontal distance between two successive riser-faces.
4. **Hand rail:** The inclined rail over the strength is known as a hand rail. It serves as a guard rail and it should be provided at a convenient height so as to give grasp to the hand during ascent and descent.
5. **Header Room:** It is the minimum clear vertical distance between the tread and overhead structure (i.e ceiling)
6. **Landing:** The horizontal platform between two flights of a stair is known as the landing. A landing facilitates change of direction and provides an opportunity for taking rest during the use of a stair.
7. **Newel post:** This is the vertical member which is placed at the ends of flights to connect the ends of strings and handrails.
8. **Nosing:** the outer projecting edge of a tread is termed as nosing. Nosing is usually rounded to give good of architectural effect to the treads and makes the staircase easy to negotiate.
9. **Pitch or Slope:** The angle of inclination of the stairs with the floor is known as pitch.
10. **Riser:** It is vertical portion of a step providing a support to the tread.

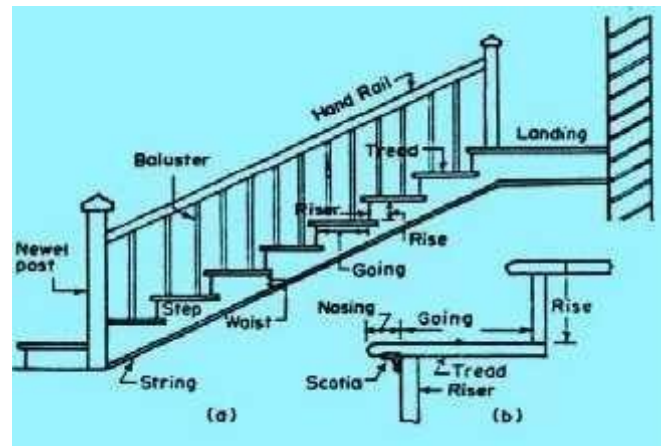



11. **Rise:** It is the vertical distance between two successive tread faces.
12. **Run:** The total length of a stair in a horizontal plane is known as the run and it includes the length of landings also
13. **Soffet:** The under surface of a stair is known as the soffet.
14. **Steps:** A portion of a stairway comprising the tread and riser which permits ascent and descent from one floor to another.
15. **Tread:** It is the upper horizontal portion of a step upon which the foot is placed while ascending or descending.
16. **String:** These are the sloping members which support the steps in a stair. They run along the slope of the stair.

#### 4.2.4 Types of Stairs (Classification)

The stairs are classified as follows

1. Straight stairs
2. Turning stairs
  - a) Quarter turn
  - b) Half turn stair (dog-legged and open-well)
  - c) Three quarter turn stairs
  - d) Bifurcate a turn
3. Circular or helical or spiral stairs
4. Geometrical stairs

notes4free.in

##### 1. Straight Stairs:

In case of a straight stair, all steps lead in one direction only. This stair runs straight between the two floors. These are used when the space available for staircase is long but narrow in width. The stair may consist of either one flight or more than one flight.

##### 2. Turning stairs:

A stair turning through one right angle is known as a quarter-turn stair. The turn being affected either by introducing a quarter-space landing or by providing winders.

Half turn stair: A stair turning through two right angles is known as a half-turn stair. A half turn stair may be of dog-legged type or open newel type.

##### Dog-legged Stair

In this type, the flights run in opposite direction and there is no space between them in plan. These stairs are used for space available for the staircase is equal to twice the width of steps. The name is given because of its appearance in sectional elevation.

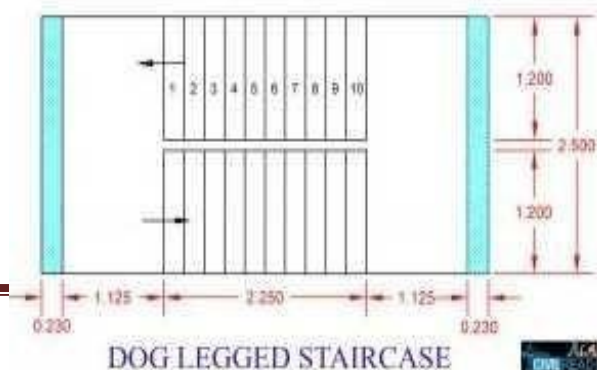

### Open Newel half turn Stairs

In this type, there will be a well or hole or opening between the flights in plan. These stairs are useful where available space for staircase has a width greater than twice the width of steps. If the width of the stairs case hall is such that it comes difficult to accommodate the number of steps in the two flights, without exceeding the maximum allowable limit of steps in each flight, a short-flight of 3 to 6 steps may be provided along the width of the hall.

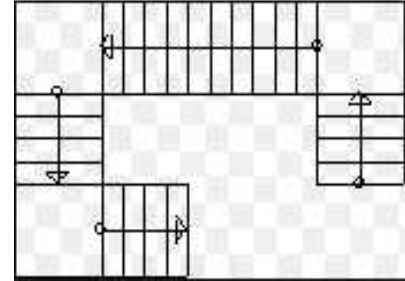

### Three quarter Turn Stairs

A three quarter turn stairs has its direction changed three times with its upper flight crossing the bottom one. It may either be newel type or open newel type. Such type of stair is used when the length of the stair room is limited and when the vertical distance between the two floors is quite large.

### Bifurcated Stairs

This type of stair is commonly used in public building at their entrance hall. The stair has a wider-flight at the bottom, which bifurcate into two narrow flights, one turning to the left and other to the right at the landing.

### Continuous Stairs

These are those which do neither have any landing nor any intermediate newel post. They are therefore, geometrical in shape. They may be of the following types.

1. Circular stairs (similar to geometrical stairs)
2. Spiral stairs
3. Helical stairs

### Spiral stairs

It is usually made either of R.C.C. or metal and is employed at a location where there are space limitations. All the steps are winders. The stair is therefore, not comfortable.

### 4.2.5 Requirements of a good stair

Stair is the vertical transportation between the floors. It should, therefore, be designed so as to provide easy, quick and safe mode of communication between the floors.

Following are the general requirements which a stair should fulfill.

A. **Design of layout:** The height of floor is generally known. The procedure for determining the number of treads and risers is as follows

1. The position of first and last risers is determined with regard to the position of doors, window or varandahs etc.
2. A convenient height of the riser is assumed
3. Number of risers = total height of floor / Height of riser
4. Number of treads in a flight = number of risers - 1

This is due to the fact that the surface of the upper floor forms the tread for the top step

### **B. Treads and Risers:**

For comfortable ascent and descent, the rise and tread of a step should be well proportioned.

The following thumb rules are followed

(Rise in cm) + (going in cm) = 40 to 45

(Rise in cm) x (going in cm) = 410 to 450 approximate

(2 x rise in cm) + (going in cm) = 60 approximately

Adopt Rise = 1.4cm and Going = 30 cm as standard, then for every 20mm(2cm) subtracted from going add 10mm(1cm) to the rise.

Thus other combination of rise and going would be

15cm x 28cm: 16cm x 26cm: 17cm x 24cm.

The staircase in a residential building should be 270mm. For public buildings, it is desirable to have a rise of not more than 180mm and a going of not less than 270mm. The wider the going, the less should be the riser and greater the rise, the less should be the going.

- C. **Width:** The width of a stair should be sufficient for two persons to pass on it simultaneously and for furniture etc. to be carried up and down the stair. The minimum width of a stair is taken as about 800mm
- D. **Pitch:** The inclination of a stair to the horizontal should be limited to 30° to 45°
- E. **Flight:** It is not desirable to provide a flight with more than 12 or at the most 15 steps and not more than 3 steps. Suitable landings should be provided to give comfort and safety to the users of the stair.
- F. **Headroom:** The provision of adequate headroom is necessity in a good stair. It should preferably not less than 2m.
- G. **Hand rail:** When a flight consists of more than 3 steps, a hand rail at least on one side is considered to be necessity. The wide stairs should be provided with hand rails on both the sides. Very wide stairs, as required for public buildings, should be provided with residential hand rail. The height of hand rail above should be approximately 800mm.
- H. **Winders:** These are to be avoided as far as possible if winders are unavoidable, they should be at the bottom rather than at the top of the flight.
- I. **Location:** The stairs should be so located that are well lighted and well ventilated and have sufficient and spacious approaches.
- J. **Materials and workmanship:** The stair should be constructed and materials and good workmanship so as to impart utility and strength to the stair.

## 4.2.6 Questions

1. Briefly explain the terms used in stairs?
2. Explain the types of stairs?
3. Explain the uses of stairs?

## 4.2.7 Outcomes

- Able to study the different types of stairs
- Able to study the terms used in stairs
- Will be knowing the types of and uses of stairs

## 4.2.8 Future Stud

[https://www.vssut.ac.in/lecture\\_notes/lecture1424085991.pdf1](https://www.vssut.ac.in/lecture_notes/lecture1424085991.pdf1)

notes4free.in

**STRUCTURE**

4.3.1 Introduction to Form work

4.3.2 Objective

4.3.3 Shoring

4.3.4 Underpinning

4.3.5 Scaffolding

4.3.6 Assignment

4.3.7 Outcomes

4.3.8 Future study

notes4free.in

**4.3.1 Introduction**

- The formwork or shuttering is a temporary ancillary construction used as a mould for the structure, in which concrete is placed and in which it hardens and matures.
- The construction of formwork involves considerable expenditure of time and materials.
- The cost of construction of formwork may be up to 20-25% of the cost of structure in building work and even higher in bridges.
- Whenever concrete is placed, it is in a plastic state. It requires to be supported by temporary supports and casing of desired shape till it becomes sufficiently strong to support its own weight. This temporary casing is known as form work.
- Forms are classified as wooden, plywood, steel, combined wood-steel bed so on. Timber is most common material used for formwork. The disadvantage of wooden formwork is the possibility of warping, swelling and shrinking of the timber. However, the defects can overcome by applying impermeable coatings to the shuttering. The coating also prevents the shuttering from adhering to concrete and hence makes the stripping easier.
- Steel shuttering is used for major work where everything is mechanized.
- Steel formwork has many advantages such as follows:
  - 1) It can be put to high number of uses.
  - 2) It provides ease of stripping.
  - 3) It ensures even and smooth concrete surface.
  - 4) It possesses greater rigidity.
  - 5) It is not liable to shrinkage.

#### 4.3.2 Objectives

- To study the form works used in construction
- To study the types formworks
- To gain the knowledge on removal of form work

#### Formwork details for RCC columns

The column formwork consists of a box prepared from four separate sides. It consists of the following main components:

1. Sheeting all round the column periphery
2. Side yokes and end yokes
3. Wedges
4. Bolts with washers

The side yokes and end yokes consists of two numbers each and are suitably spaced along the height of the column. The side yokes are

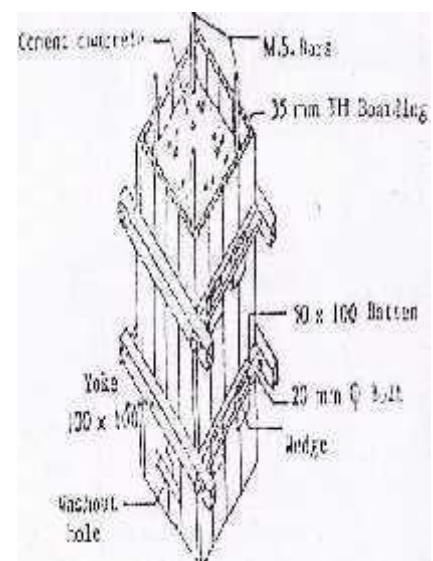

comparatively of heavier section, and are connected together by two long bolts of 16mm dia. Four wedges, one at each corner are inserted between the bolts and the end yokes. The sheathing is nailed to the yokes.

The important features of the formwork for RCC columns are:

1. The formwork should be the quick filling of the concrete.
2. The spacing of yokes is about one meter. But it should be carefully determined by working out the greatest length of the formwork which can safely resist the load coming on the formwork.
3. Depending upon the shape the column, the box can be suitably prepared.
4. A wash of water is given to the inside of the form work just before starting the laying of concrete.
5. A hole is generally provided at the bottom of the formwork of column to remove the debris which might have fallen before concrete is placed. This hole is termed as the cleanout hole and washout hole and it is filled up before placing of the concrete starts.

### Formwork details for Beams

Fig. shows the formwork for beam and slab floor. The slab is continuous over a number of beams.

The slab is supported on 2.5cm thick sheathing laid parallel to the main beams. The sheathing is supported on wooden battens which are laid between the beams, at some suitable spacing. The side forms of the beam consist of 3cm thick sheathing. The bolt from sheathing of the beam form may be 5 to 7cm thick. The ends of the battens are supported on the ledges which is fixed to the cleats throughout the length, cleats 10cm x 2cm to 3m are fixed to the side forms at the same spacing as that of battens, so that battens may be fixed to them.

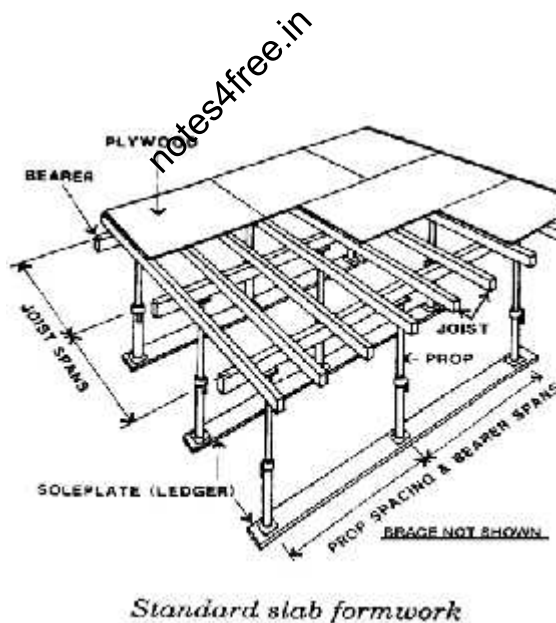
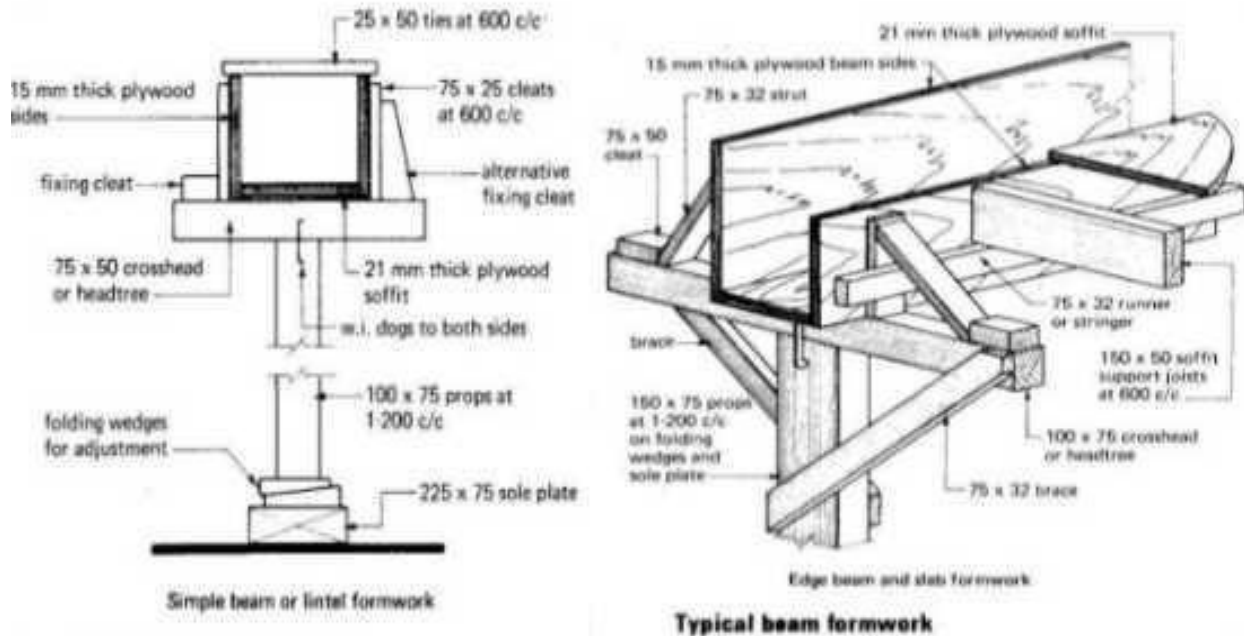

**Requirements of a Good Formwork**

1. It should be strong enough to withstand all types of dead, live loads, such as self weight. Weight of reinforcement, weight of wet concrete, load due to workmen, construction equipment, other incidental loads and forces caused by placement and consolidation of concrete, imposed upon i.e. during and after curing of concrete.
2. It should be rigidity constructed and efficient propped and braced, so as to retain its shape without undue deflection.
3. Joints in the formwork should be tight against leakage of cement grout.



4. Material of formwork should be cheap, easily available and should be suitable for reuse several times.
5. The formwork should be set accurately to the desired line exposed to sun, rain or water during concreting.
6. Formwork should rest on a firm base.

### **Removal of Formwork**

The operation of removing of the formwork is commonly known as stripping. The forms which can be conveniently re-used are known as the panet forms. The forms which cannot be re-used because of their non-standard shapes are known as stationary forms.

### **4.3.3 Shoring**

Shoring is the construction of a temporary structure to support temporarily an unsafe structure. These provide lateral support to the walls.

Some of the circumstances under which the shoring is required are as follows.

1. When the cracks developed due to unequal settlement of foundation in a wall are to be repaired.
2. When a wall shows signs of bulging out due to bad workmanship.
3. When the adjacent structure is to be dismantled.
4. When the defective walls of a building are to be dismantled and rebuilt and support is necessary to the floor and roofs connected to that wall.
5. When the large openings are required to be made in the main walls of an existing building.

### **Types of shoring**

1. Raking or inclined shores
2. Flying or horizontal shores
3. Dead or vertical shores

#### **1. Raking or inclined shores**

In this arrangement the inclined supports are given to the external walls from the ground as shown in fig.3.9. In this method, inclined members, called rakers are used to give lateral support to the wall.

A raking shore consists of the following components

- i. Rakers or inclined members
- ii. Wall plate
- iii. Needles
- iv. Cleats
- v. Bracing

#### vi. Sole plate

The wall plate, about 20 to 25cm wide and 5 to 7.5cm thick is placed vertically along the face the wall and is secured by means of needles of 10cm x 7.5cm section which penetrate into the wall for a distance of about 150mm. In order that the needles do not get sheared off due to the thrust of the rakes, the needle are further strengthened by means of cleats which are nailed directly to the wall plate.

Rakers are placed against the needles in such a way that the centre line of the raker and the wall meet at the floor level. Thus, there will be one raker corresponding to each floor. These rakers are inter-connected by streets to prevent their building. At their base (or feet) the rakers are supported by a sole piece or sole plate embedded into the ground by means of iron dog.

In places where more rakers are provided, they are bound together by means of hoop iron or braces. The inclination of the outer raker to the ground should vary between 60 to 75°. The sets shores should placed at 3 to 4.6m centre to center length.

#### **Flying or Horizontal Shores**

In this arrangement the horizontal supports are given to parallel walls which have become unsafe due to the removal or collapse of the intermediate building.

All types of arrangements of supporting the unsafe structure in which the shores do not reach the ground fall under this category. If the walls are quite near to each other (distance up to 9m), single flying shore can be constructed (fig 5.10).

It consists of wall plates, needles, cleats, streets, horizontal shore, straining pieces and folding double flying shore may be provided.

In this system, the wall plates are placed against the wall and secured to it. A horizontal street is placed between the wall plates and is supported by a system of needle and cleats. The inclined streets are supported by the needle at their top and by straining pieces at their feet.

#### **Dead or Vertical Shores**

This type of shoring consists of vertical members known as dead shores supporting horizontal members known as needles.

The needles transfer the load of the wall etc. to the dead shores. Such shoring is provided to save the following purposes or under the following circumstances.

1. The lower part of the wall has become defective
2. The lower part of the wall is to be rebuilt or reconstructed.
3. The large openings are to be made in the existing.

The dead shore consists of an arrangement of beams and posts which are required to support the weight of the structure above and transfer the same to the ground on firm foundation below.

When openings in the wall are to be made, holes are cut in the wall at such a height so as to allow sufficient space for insertion of the beam or girder that will be provided permanently to carry the weight of the structure above.

Distances at which the holes are cut depend upon the type of masonry and it varies from 1.2m centre to 1.8m centre. Beams called needles are placed in the holes and are supported by vertical props called dead shores at their ends on either side of the wall.

The needle may be of timber or steel and are of sufficient section to carry the load from above. The props are tightened up by folding wedge provided at their bases while the junction between the prop and the needle is secured with the help of dogs.

#### 4.3.4 Underpinning

The placing of new foundation below an existing foundation in the process of strengthening the existing foundation is known as the underpinning of foundations.

Underpinning may be required to save the following purposes.

1. To strengthen the shallow foundation of existing building when a building with deep foundation is to be constructed adjoining it.
2. To strengthen the existing foundation which has settled and caused cracks in the wall
3. To deepen the existing foundation (resting on poor strata) so as to rest it on deeper wet strata of higher bearing power.
4. To construct a basement in the existing building.

#### Methods of Underpinning

Following are the methods of underpinning.

1. Pit method
2. Pile method

##### 1. Pit method:

In this method, the entire length of the foundation to be underpinned is divided into sections of 1.2 to 1.5m length. One section is taken up at a time. For each section, a hole is made in the wall, above the plinth level, and needle is inserted in the hole. Needles may be either of stout timber or steel section"

Bearing plates are placed above the needle to support the masonry above it. Needle is supported on either side of the wall on crib supports (wooden blocks) with screw jacks. The foundation pit is then extended upto the desired level and new foundation is laid.

When the work of one section is over, work on next to next section is taken up i.e, alternate section are underpinned in the first round, and then the remaining sections are taken up.

If the wall to be underpinned is weak, raking shores may be provided. Following precautions are necessary:

- One section should be excavated at a time.

- The alternate section should be taken in succession.
- If the length of wall is more, the underpinning is started from the middle and it is then extended in both the directions.
- The proper timbering should be provided for the trench.
- It is desirable to carry out the new foundation work in concrete.
- If space to support needle on outside is not needles may be adopted.

## 2. Pile Method

In this method, piles are driven at regular interval along both the sides of the wall. Generally bore holes piles or under piles may be used. The piles are connected by concrete or steel needles, penetrating through the wall. These beams incidentally act as pile caps also. This method is very much useful in clayey soils, and also in water-logged areas.

### 4.3.5 Scaffolding

Scaffold is a temporary rigid structure having plate forms raised up as the building increases in height i.e, when the height above floor level exceeds about 1.50m a temporary structure, usually of timber, is erected close to the work to provide a safe working platform for the workers and to provide a limited space for the storage of building materials. It is useful in construction, demolition, maintenance or repair works.

#### Types of Scaffolding

1. Cantilever or needle scaffolding
2. Single scaffolding
3. Suspend scaffolding
4. Trestle scaffolding
5. Steel scaffolding
6. Patented scaffolding

### 4.3.6 Questions

1. Briefly explain the terms used in form works?
2. Explain the types of form works for RCC and slab?
3. Explain the types of scaffoldings?

### 4.3.7 Outcomes

- Able to study the form works in detail
- Able to distinguish different types of form works for different types of construction

### 4.3.8 Further readings

[https://www.vssut.ac.in/lecture\\_notes/lecture1424085991.pdf1](https://www.vssut.ac.in/lecture_notes/lecture1424085991.pdf1)

Module – 5

**Plastering, Pointing, Damp-proofing & Painting**

**Structure**

- 5.1 Introduction
- 5.2 Objective
- 5.3 Purpose of Plastering
- 5.4 Materials for Plastering
- 5.5 Methods for Plastering
- 5.6 Defects in Plastering
- 5.7 Damp proofing
- 5.8 Causes for dampness
- 5.9 Effects for dampness
- 5.10 Methods for damp-proofing
- 5.11 Introduction to Paintings
- 5.12 Questions
- 5.13 Outcomes
- 5.14 Future study

notes4free.in

## 5.1 Introduction

Plaster is a building material used for coating walls and ceilings. Plaster starts as a dry powder similar to mortar or cement and like those materials it is mixed with water to form a paste which liberates heat and then hardens.

## 5.2 Objectives

- To study the terms used in plastering
- To study the types of plastering
- To gain the knowledge on paints

## 5.3 Purpose of Plastering

1. Resistant to impacts expected in use.
2. Free of irregularities.
3. Consistent in texture and finish.

## 5.4 Materials for Plastering

### Admixtures

Plasticizers or workability agents: Do not use in cement plasters.

The use of admixtures should not be permitted unless there is confidence that there will be an improved outcome. Their use in lieu of suitable sands should be resisted unless no reasonable alternative is available.

### Aggregates

Sand: To be fine, sharp, well-graded sand with a low clay content and free from efflorescing salts.

### Cement

Standard: AS 3972. Type: GP.

Type GP is general purpose cement. Other types are defined in the standard and there is a separate standard for masonry cement which contains plasticizers and other additives. The mixes specified here are for Portland cement Type GP. Do not permit the substitution of masonry cement for general purpose cement or of plasticizers for lime without full.

### Coloring products

Coloring pigments should be added for about 5% by weight of cement.

## 5.5 Methods for Plastering

### Lime Plastering

Lime has been used as a building material for centuries. It has many unique properties that make it as relevant and beautiful a material as it ever was. Ornate Interiors are highly skilled in this ancient technique, and can apply lime plaster either directly onto brick or masonry („on the hard“) or onto wooden laths.

The Wooden laths, 1¼ wide x ¼" thick (usually oak, chestnut or Scots pine) can be either sawn or riven (i.e. traditionally hand-made) and are thoroughly dampened before plastering. If mortar is applied to dry laths they are likely to swell, causing them to bow either inwards or outwards.

Plaster is applied in three coats, starting with a „scratch coat“ that is a coarse combination of products mixed with animal hair. The rough surface is keyed to create good adhesion for the subsequent layer. Then a „straightening coat“ is applied to even out the surface, building up to the „finishing coat“, producing a fine smooth finish.

There are many colloquial and historical names for the different layers of three coat lime plastering just as there are many different recipes for the plastering material itself. It is a long process demanding dedicated craftsmen with exceptional skills, and the time taken is affected by the weather, the environment and the materials. It is a complex technique but the results are superb.

### Solid Plastering

Application of solid plaster to brick, block and cement substrates or to solid plasterboard is within our skills base. We use contemporary or traditional plastering materials, giving extra attention to angles, reveals and openings for a superb finish. Solid plastering on exteriors is common, as a form of rendering or on building facades. Colored render can be used to reduce decorating costs. We are proud that our quality is second to none.

### 5.6 Defects in Plastering

- 1. Cracks:** Cracks appear on the plastered surface in the form of thin lines or wider cracks. They are due to shrinkage of thick plaster or due to poor workmanship. Cracks can be prevented by proper curing and by keeping thickness of plaster as uniform.
- 2. Efflorescence:** Due to soluble salts present in the brick or mortar. This defect can be avoided by washing the surface with zinc sulphate solution and water.
- 3. Falling out of plaster:** It is due to inadequate water bondage, water absorption by the dry wall. To avoid this defect the joint should be properly cleaned and surface of the wall should be properly watered before plastering. Minimum 10 days curing should be done for the plastered surface

### 5.7 Damp Proofing

An application of water-resisting treatment or material to the surface of concrete or masonry wall in order to prevent the passage or absorption of water or moisture.

### **5.8 Causes of Dampness**

Following are the various causes of dampness in buildings.

1. Rising of moisture from the ground
2. Action of rain
3. Rain beating against external walls
4. Condensation
5. Miscellaneous

#### **1. Rising of moisture from the ground**

The ground on which the building is constructed may be made of soils which easily allow the water to pass. Usually the building materials used for the foundations, absorb moisture by capillary action. Thus the dampness finds its way to the floor through the substructure.

#### **2. Action of rain**

If the faces of wall, exposed to heavy showers of rain, are not suitably protected, they become the sources of entry of dampness in and similarly the leaking roofs also permit the rain water to enter a structure.

#### **3. Rain beating against external walls**

If balconies and Chejja projections do not have proper outward slope, water will accumulate on these and could ultimately enter the walls through their junction. The moisture travel would completely surface interior decoration of the wall.

#### **4. Condensation**

The process of condensation takes place when humid air is cooled. Due condensation of atmospheric moisture, water is deposited on the walls, floors and ceilings. This moisture may cause dampness.

#### **5. Miscellaneous**

If the structure is located on a site which cannot be easily drained off the water, the dampness will enter the structure (i. e, due to poor drainage).



Imperfect orientation: walls getting less sunshine and heavy showers may cause dampness.  
Imperfect roof slope: Very flat slope leads to dampness

### 5.9 Effects of Dampness

1. It causes efflorescence which may ultimately result in disintegration of bricks, stones, tiles etc.
2. It may result in softening and crumbling of plaster. The unsightly patches are formed on the wall surface and ceilings.
3. The electrical fittings are deteriorated and it may lead to leakage of electricity and consequent danger of short circuiting.
4. It may result warping, buckling and rotting of timber.
5. It may leads to corrosion of metals.
6. It promotes growth of termites.
7. It breeds mosquitoes and creates unhealthy living conditions for the occupants.
8. The floorings get loosened because of reduction in the adhesion when moisture enters through the floor.
9. The materials used for wall decoration are damaged.

### 5.10 Methods of Damp-proofing

There are various methods of damp-proofing and depending upon the nature of surface, situation of the structure and amount of dampness, Following are the methods or measures adopted to prevent entry of dampness

1. Membrane damp proofing
2. Integral damp proofing
3. Surface treatment
4. Guniting

#### Membrane Damp-proofing

This consists in providing layer of membrane of water repellent material between the source of dampness and the part of the structure adjacent to it. It may comprise of materials like bituminous fells mastic asphalt, epoxy, polymers, plastic or polythene sheets etc.

General principles to be observed while laying D.P.C. are as under

- i. The D.P.C. should cover full thickness of walls.

- ii. The mortar bed which is prepared to receive the horizontal damp-proofing course should be even and leveled and free from projections so that the damp-proofing course is not damaged.
- iii. At junction and corners of walls, the horizontal D.P.C. should be laid continuous.
- iv. When a horizontal D.P.C. is to be continued to a vertical face, a cement concrete fillet 75mm in radius should be at the junction, prior to the treatment

### **Integral Damp Proofing**

- 1) This consists in adding certain water-proofing compounds with the concrete mix, so that it becomes impermeable. Thus water proofing compounds may be in three forms
- 2) Compounds made from chalk, talc, fuller's earth which may fill the voids of concrete under the mechanical action principle.
- 3) Compounds like alkaline silicon, aluminum, sulphate, and calcium chlorides etc which react chemically with concrete to produce WPC.
- 4) Compounds like soap, petroleum oils, fatty acids compounds such as stearates of calcium, sodium, ammonia etc work on water repulsion principle.

### **Surface treatment**

This consists in filling up the pores of the surfaces subjected to dampness. The use of water repellent metallic soaps such as calcium and aluminum and stearates is much effective in protecting the building against the ravages of heavy rain.

The walls plastered with cement, lime and sand mixed in proportions of 1:1:6 as found to save the purpose of preventing dampness in wall due to rain effectively.

### **Guniting**

This consists in depositing an impervious layer of rich cement mortar over the surface to be water proofed. The operation is carried out by use of machine known as cement gun.

The surface to be treated is first thoroughly cleaned of dirt, dust, grease or loose particles and wetted properly. Cement and sand usually taken in proportion of 1:3 to 1:4 are then fed into the machine. This mixture is finally shot in the prepared surface under a pressure of 2 to 3 kg/cm<sup>2</sup>. The nozzle of the machine is kept at a distance about 75 to 90 cm from the surface to be guniting. The mortar mix of desired consistency and thickness can be deposited to get an impervious layer.

### **5.11 Introduction to Paintings**

Painting is the practice of applying paint, pigment, color or other medium to a surface (support base). The medium is commonly applied to the base with a brush but other objects can be used.

## 5.12 Assignment

1. Briefly explain the terms used in plastering?
2. Briefly explain about paints?
3. Explain the defects in plastering?

## 5.13 Outcomes

- Able to study the plastering in detail
- Able to study the paints in details
- Will be able to know the defects in plastering

## 5.14 Future Study

<http://nptel.ac.in/syllabus/105102088/>

notes4free.in